

# Power Awning Pro

**3316518.XXX, 3316519.XXX, 3317114.XXX, 3317115.XXX**

INTRODUCTION .....	2
IMPORTANT SAFETY INSTRUCTIONS AND DOCUMENT SYMBOLS.....	2
A. Recognize Safety Information.....	2
B. Understand Signal Words.....	2
C. Supplemental Directives.....	2
D. General Safety Messages .....	2
GENERAL INFORMATION .....	3
A. Receiver Control Range .....	3
INSTALLATION .....	3
A. Installing The Receiver .....	3
B. Programming The Remote Control.....	4
C. Programming The Vibration Sensor (If Applicable).....	5
D. The Vibration Sensor (If Applicable).....	6
OPERATION .....	7
A. The Function Of The Remote Control.....	7
B. Adjusting The Vibration Sensor (If Applicable).....	7
C. Other Useful Information.....	8
DISPOSAL .....	8
WARRANTY INFORMATION .....	8
A. United States and Canada .....	8
B. All Other Regions .....	8



**Read these instructions carefully. These instructions MUST stay with this product.**  
Dometic Corporation reserves the right to modify product appearances and specifications without notice.

# INTRODUCTION

The Power Awning Pro system (hereinafter referred to as “unit” or “Product”) is designed and intended for installation in a Recreational Vehicle (hereinafter referred to as “RV”) during or after the RV manufacture.

The Product kit is available for order with various components so while some graphics may show different components, they still illustrate the correct procedure. All components that were not originally ordered can be purchased as an add-on or upgrade.

Dometic Corporation reserves the right to modify appearances and specifications without notice.

# IMPORTANT SAFETY INSTRUCTIONS AND DOCUMENT SYMBOLS

This manual has safety information and instructions to help you eliminate or reduce the risk of accidents and injuries.

## A. Recognize Safety Information



This is the safety alert symbol. It is used to alert you to potential physical injury hazards. Obey all safety messages that follow this symbol to avoid possible injury or death.

## B. Understand Signal Words

A signal word will identify safety messages and property damage messages, and will indicate the degree or level of hazard seriousness.

**WARNING** indicates a hazardous situation that, if **NOT** avoided, could result in death or serious injury.

**CAUTION** indicates a hazardous situation that, if **NOT** avoided, could result in minor or moderate injury.

**NOTICE** is used to address practices **NOT** related to physical injury.

## C. Supplemental Directives



Read and follow all safety information and instructions to avoid possible injury or death.

Read and understand these instructions before installation, use, service, or maintenance of this product. Incorrect installation, operation, service, or maintenance of this product can lead to serious injury.

The installation **MUST** comply with all applicable local or national codes, including the latest edition of the following standards:

### U.S.A.

- ANSI/NFPA70, National Electrical Code (NEC)
- ANSI/NFPA 1192, Recreational Vehicles Code

### CANADA

- CSA C22.1, Parts I & II, Canadian Electrical Code
- CSA Z240 RV Series, Recreational Vehicles



Indicates additional information that is not related to physical injury.

## D. General Safety Messages

**WARNING** Failure to obey the following warnings could result in death or serious injury:

- This product **MUST** be installed/serviced by a qualified service technician.
- Do **NOT** modify this product in any way. Modification can be extremely hazardous.
- **IMPACT OR CRUSH HAZARD.** This product should be installed in a controlled environment (inside). Do **NOT** install product during windy conditions, or when wind is expected. Otherwise, product could move unpredictably, become unstable, and could detach, bend, or collapse.

**NOTICE** Compatible **ONLY** with 9100, 9200 and 9500 power awnings and associated hardware.

# GENERAL INFORMATION

## REQUIRED HARDWARE

(2) 3/16" x 1/2" Pop Rivet (Optional – Installer-Supplied)

## BASIC COMPONENTS

3317114.201 Wireless Receiver

- |                              |                                   |
|------------------------------|-----------------------------------|
| • Receiver Wire Harness      | • Dry Contact Switch Wire Harness |
| • 3316518.201 Remote Control | • Miscellaneous Wire Connectors   |
| • Dry Contact Switch (Power) |                                   |

## OPTIONAL COMPONENTS AND KITS

3316519.205 Vibration Sensor (Black)	3316519.202 Vibration Sensor (White)
--------------------------------------	--------------------------------------

## REQUIRED TOOLS

Drill	Phillips Screwdriver/Bit
#11 (0.191") Drill Bit	7/16" Hex Nut Driver/Bit
Riveting Tool	Needle Nose Pliers
Flat-Bladed Screwdriver/Bit (Small)	Wire Cutter

### A. Receiver Control Range

	L1 IN THE AIR	L2 WITH CONCRETE WALLS	EMISSION FREQUENCY
12 V	200 m (656.17 ft)	35 m (114.83 ft)	433.92 MHz

# INSTALLATION

**⚠ WARNING** ELECTRICAL SHOCK HAZARD. Disconnect 120 VAC power from RV. Failure to do so could result in death or serious injury.

**NOTICE** Failure to obey the following directions could result in damage to the unit or property:

- Install a 15 A fuse (installer supplied) at fuse panel for positive (+) 12 VDC power supply (RED wire) to product.
- Disconnect the positive (+) 12 VDC terminal from supply battery.
- Disconnect power for ALL procedures under this section. Use a grommet (installer supplied) or equivalent protection when routing wire through the RV's roof, floor, or walls.

### A. Installing The Receiver

1. Determine the receiver location, and then secure the receiver to the wall or cabinet using screws (installer supplied).
2. Route the wiring.

**(i)** If using dry contact switches, route the installer-supplied wiring inside the RV from the receiver location to the dry contact switch installation site.

3. Make the electrical connections according to the wiring diagram provided (FIG. 1).

**(i)** If this unit is being added to an existing awning with LEDs, the existing LED switch must be disconnected and reconnected according to the wiring diagram provided (FIG. 1). If the existing LED switch is not disconnected, the LED will not function.

# INSTALLATION

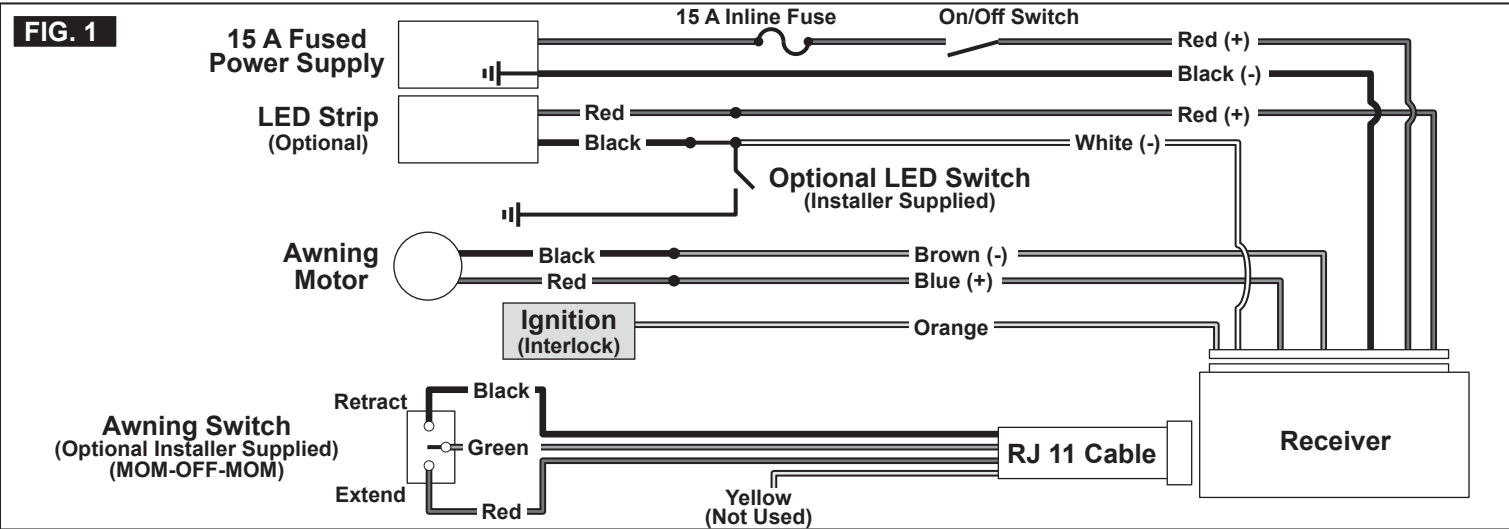

**⚠ WARNING** FIRE OR ELECTRICAL SHOCK HAZARD. For all wire connections, use only NEC-approved connectors and terminals that are appropriately sized for the wire gauge. Failure to do so could result in death or serious injury.

**NOTICE** Failure to use NEC-approved connectors and terminals of the appropriate size could result in property damage.

## B. Programming The Remote Control

**i** Complete each programming step within four seconds of the previous step to keep the receiver in pairing mode. If the receiver resets, restart the programming process.

- Disconnect all power to the receiver and wait at least ten seconds before beginning the programming process.

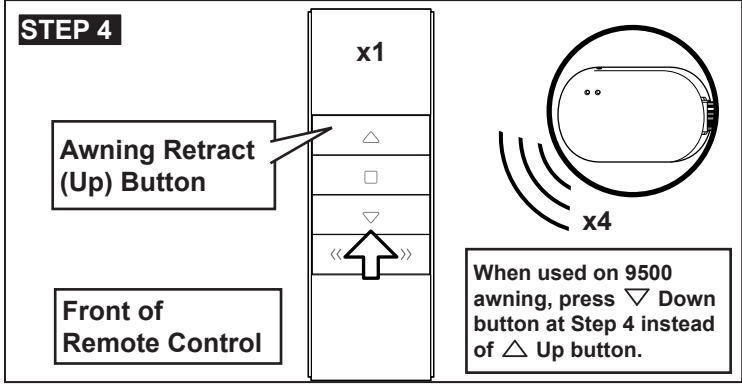
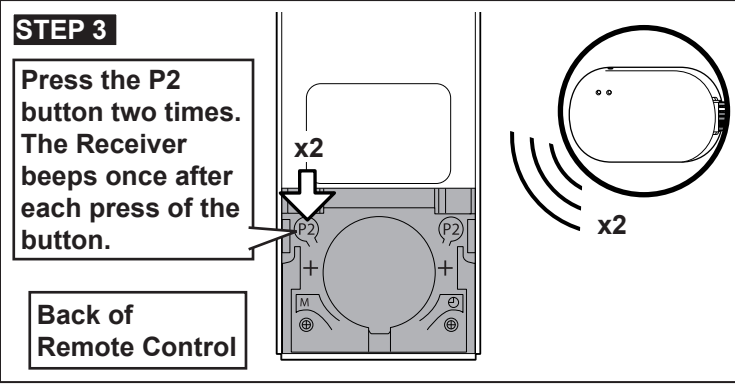
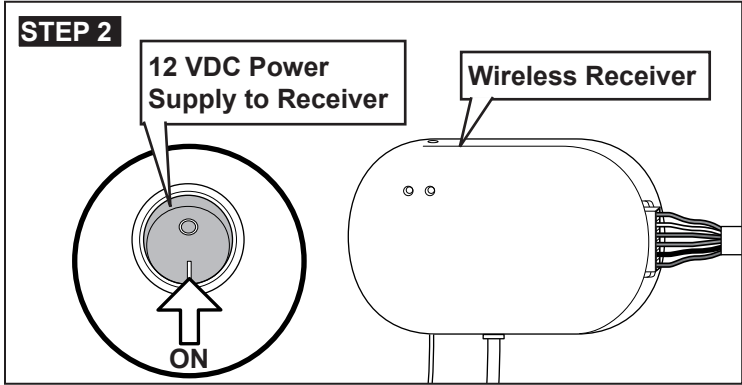
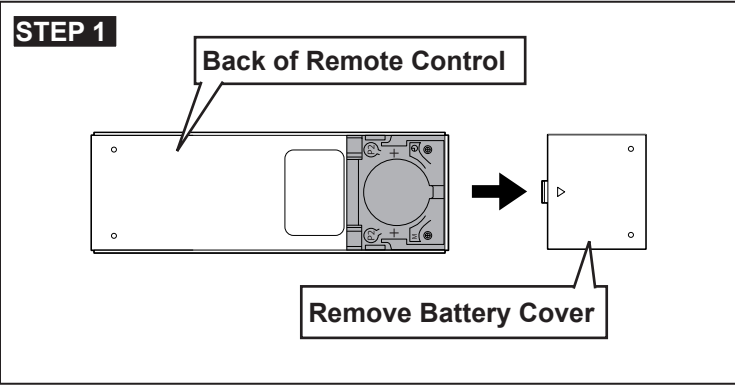

**⚠ WARNING** IMPACT OR CRUSH HAZARD. Make sure the awning retract button and the awning extend button operate the awning in the intended direction. Failure to obey this warning could result in death or serious injury.

- Refer to "A. The Function Of The Remote Control" on page 7 to test the remote control.

**i** When STEP 4 is completed, proceed immediately to "C. Programming The Vibration Sensor (If Applicable)" on page 5.

# INSTALLATION

## C. Programming The Vibration Sensor (If Applicable)

**i** Complete each programming step within four seconds of the previous step to keep the receiver in pairing mode. If the receiver resets, restart the programming process.

- When installing a vibration sensor, complete the steps in "B. Programming The Remote Control" on page 4 then start with STEP 1 of this procedure without delay.

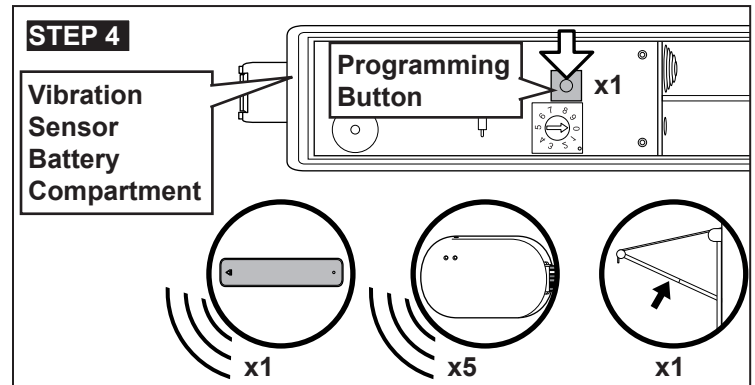
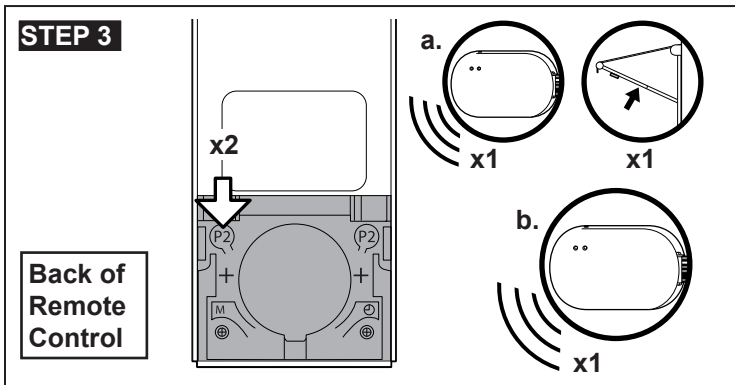
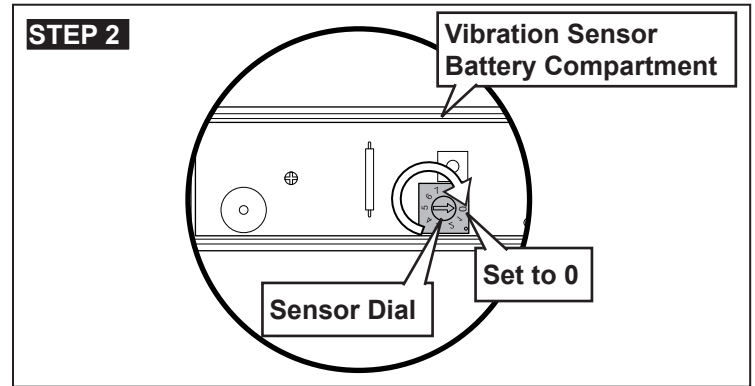
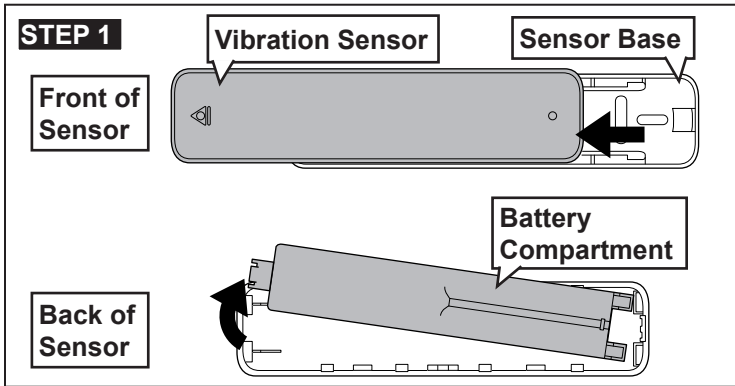

- Press the P2 button once. The wireless receiver beeps once and the awning jogs.
- Press the P2 button a second time. The receiver beeps once.

- Press the vibration sensor programming button. The sensor beeps once, the wireless receiver beeps five times, and the awning jogs.

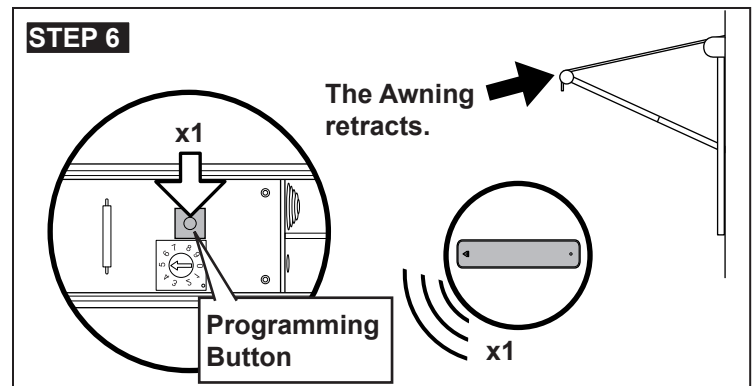
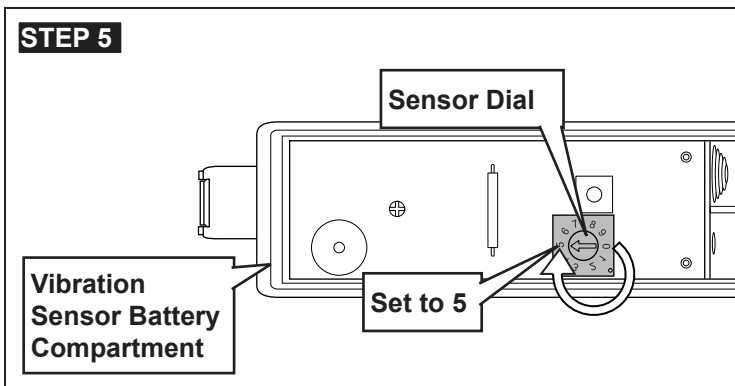

- Set the vibration sensor dial to the desired level of detection (see Operation, "B. Adjusting The Vibration Sensor (If Applicable)" on page 7).
- Press the vibration sensor programming button once. The sensor beeps once, and the awning retracts.

# INSTALLATION

## D. The Vibration Sensor (If Applicable)

**⚠ WARNING** IMPACT OR CRUSH HAZARD. This product should be installed in a controlled environment (inside). Do **NOT** install product during windy conditions, or when wind is expected. Otherwise, product could move unpredictably, become unstable, and could detach, bend, or collapse.

- Fully close the awning.

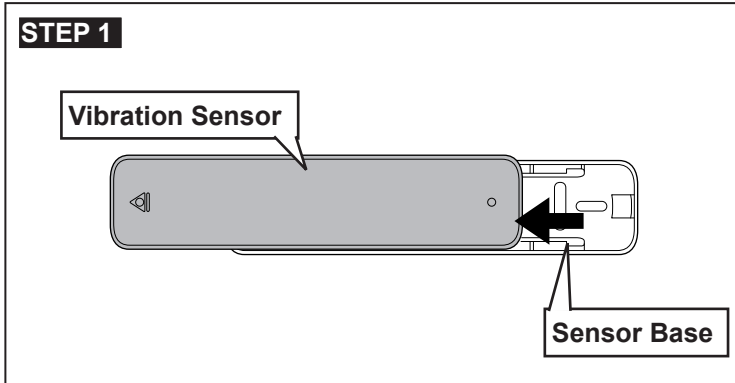

### 9100 Awnings (for 9200 awnings, use step 3)

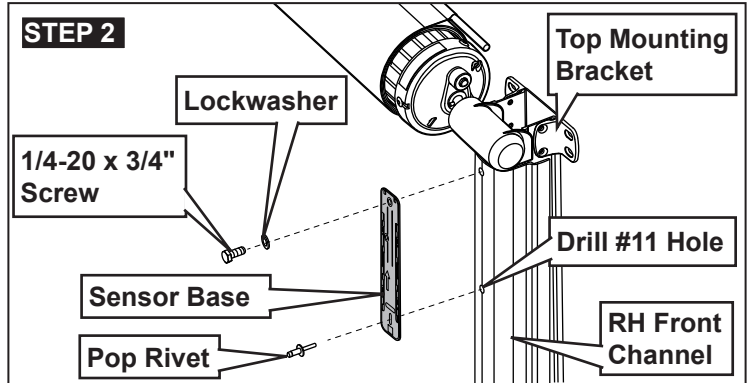

- Remove and reuse the screw and lock washer on the front channel to install the vibration sensor base.
- If using a secondary securement (installer supplied pop rivet), open the awning far enough to remove the top wire cover from the front channel. Remove the wire cover to the motor wire and pull it out of the way to avoid damaging the wire. Reconnect after mounting the vibration sensor base.
- Re-install the vibration sensor onto the sensor base.

### 9200 Awnings

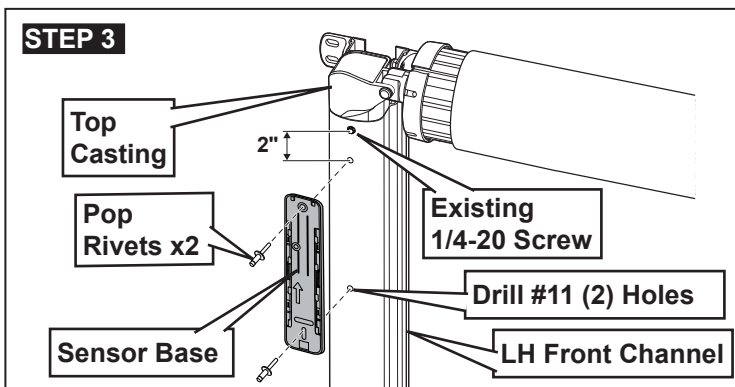

- Using the top hole in the left hardware front channel as a reference, measure down 2 inches, then mark the mounting hole locations using the sensor base as a template.
- Drill two #11 holes at the marked hole locations in the LH front channel.
- Use installer-supplied pop rivets to attach the sensor base to the LH front channel.
- Re-install the vibration sensor onto the sensor base.

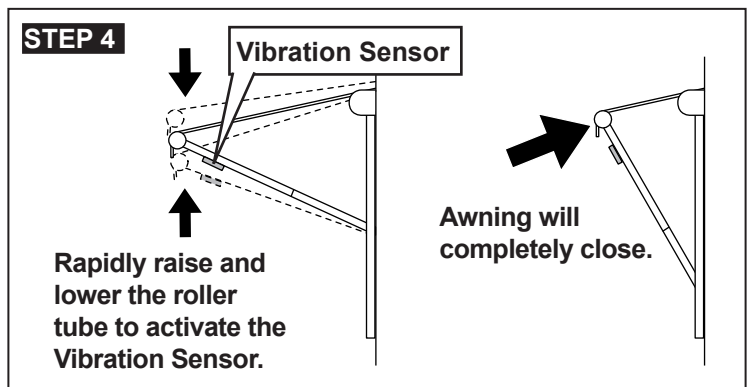

Rapidly raise and lower the roller tube to activate the Vibration Sensor.

Awning will completely close.

**i** No direct correlation exists between the sensitivity settings on this sensor and true wind speed. The vibration sensor will close the awning any time the motion in the attached hardware arm reaches the pre-set level regardless of the cause of this motion. Wind speed, angle of attack, and the size of the awning are only a few factors that can affect how an awning reacts to environmental conditions.

**i** Refer to "B. Adjusting The Vibration Sensor (If Applicable)" on page 7 if the sensor fails to activate or the sensor is too sensitive.

# OPERATION

## A. The Function Of The Remote Control

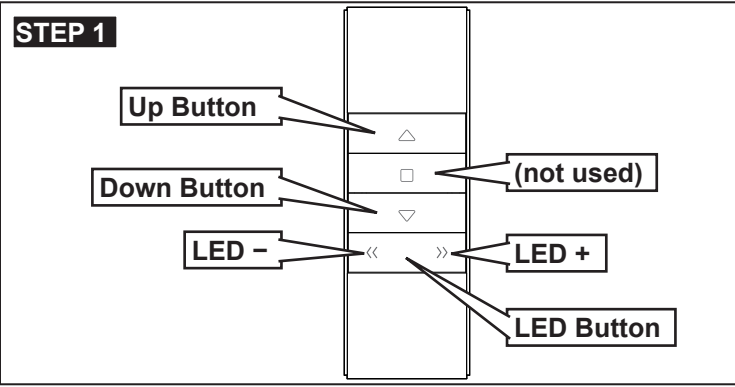

BUTTON	FUNCTION
Up	Retracts the awning when the button is held
Stop	Not used in this application
Down	Extends the awning when the button is held
LED	Turns LED light(s) on and off
LED -	Dims LED light(s)
LED +	Brightens LED light(s)

**i** For Motorized RVs Only: Make sure the awning automatically closes when starting the RV.

## B. Adjusting The Vibration Sensor (If Applicable)

**⚠ WARNING** IMPACT OR CRUSH HAZARD. Keep your hands, arms, head or torso clear of the awning hardware during periods of rain, wind, etc. These conditions may cause the vibration sensor to unexpectedly activate and retract the awning. Failure to do so could result in death or serious injury.

**NOTICE** Failure to obey the following directions could result in damage to the unit or property:

- Do **NOT** rely on the vibration sensor to prevent damage to the awning. The awning should **ALWAYS** be closed when unattended or when severe weather, such as strong rain, wind, etc., is expected.
- Do **NOT** hang any items from, or block the travel of, the hardware arms or awning when the vibration sensor is installed.

**i** The sensitivity of the vibration sensor can be set from 1 (most sensitive) to 9 (least sensitive). When the sensor is separated from the base, settings 0 and 5 are used for programming. When the sensor and the base are assembled together and the sensor senses the magnet, settings 0 through 9 can be used for active vibration settings. A setting of 0 will disable the sensor.

- Refer to "D. Mounting The Vibration Sensor (If Applicable)" on page 6 to remove the vibration sensor from the front channel.

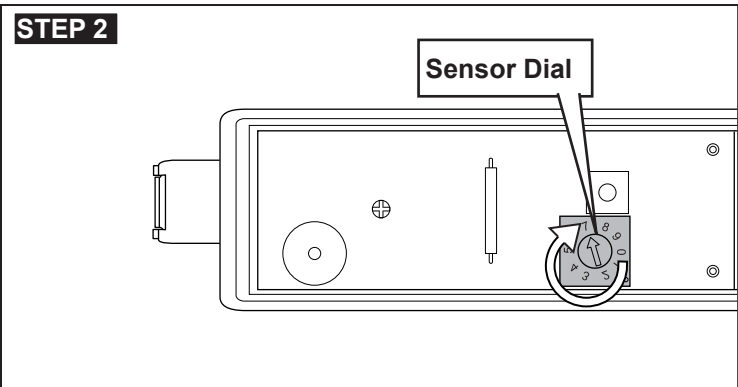
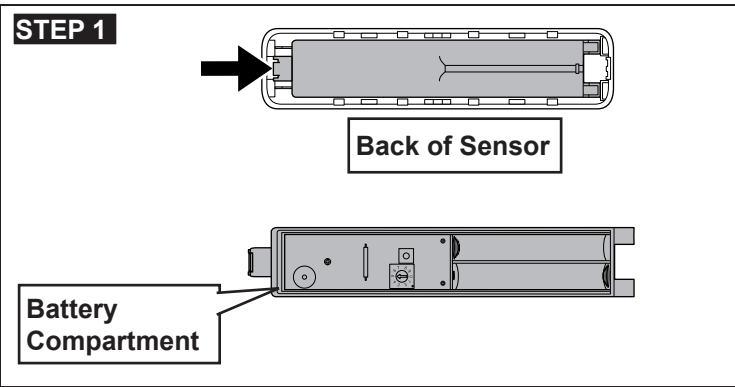

**NOTICE** **ALWAYS** confirm functionality of the vibration sensor after any changes or adjustments are made. Refer to Installation STEP 6 to test the vibration sensor operation.

# OPERATION

## C. Other Useful Information

- For safety purposes, the vibration sensor sends a signal to the receiver every 60 minutes to confirm functionality. If for any reason (removal, low battery, etc), that signal is not received after 60 minutes, the awning will retract automatically.
- The vibration sensor will not function if not attached to the sensor base.
- To extend the awning, depress the down button until the awning is fully deployed. Then, releasing the down button will cause the awning to stop, and jog back to the final use position.
- The LED output is protected by a 3 A auto-reset fuse. It will protect the LED strip in the event of a short or over-current condition. If one of these conditions occur:
  - a. Disconnect the power using the on/off switch.
  - b. Determine and fix the cause of the blown fuse.
  - c. Turn the unit on using the on/off switch.

# DISPOSAL

Place the packaging material in the appropriate recycling waste bins, whenever possible. Consult a local recycling center or specialist dealer for details about how to dispose of the product in accordance with all applicable national and local regulations.

# WARRANTY INFORMATION

Refer to the sections below for information about warranty and warranty support in the US, Canada, and all other regions.

## A. United States and Canada

Limited warranty available at [www.dometic.com/warranty](http://www.dometic.com/warranty).

If you have questions, or to obtain a copy of the limited warranty free of charge, contact:

DOMETIC CORPORATION  
CUSTOMER SUPPORT CENTER  
1120 NORTH MAIN STREET  
ELKHART, INDIANA, USA 46514  
1-800-544-4881 OPT 3

## B. All Other Regions

The statutory warranty period applies. If the product is defective, please contact the manufacturer's branch in your region (see the back of the instruction manual for the addresses) or your retailer.

For repair and guarantee processing, please include the following documents when you send in the device:

- A copy of the receipt with purchasing date
- A reason for the claim or description of the fault