



BY  LIPPERT



# Solera<sup>®</sup> Universal Hardware Power Awning to Solera 12V Power Awning (For Aftermarket Applications)

## Table of Contents

<b>Introduction</b> .....	2
System Information .....	2
Safety Information .....	2
<b>Parts List</b> .....	2
<b>Preparation</b> .....	3
Resources Required .....	3
<b>Conversion</b> .....	3
<b>Wiring</b> .....	9
<b>Operation</b> .....	10
Extending the Awning .....	10
Retracting the Awning .....	10
Adjusting Pitch .....	10
<b>Troubleshooting Chart</b> .....	11
<b>Troubleshooting</b> .....	12
Manual Override .....	12
<b>Maintenance</b> .....	12
Fabric Care .....	12



# Solera® Universal Hardware

## Power Awning to Solera 12V Power Awning

(For Aftermarket Application)

## Introduction

### System Information

The Solera® 12V Power Awning features an internal motor to steadily operate the awning. Additionally, the pitch arm assembly allows for rain dump and adjustable pitch features. The pitch arm assembly also provides added stability.

**NOTE:** The Lippert Solera Universal Hardware kit for a power to power conversion will **ONLY** fit Dometic and Carefree awnings.

Additional information about this product can be obtained from [lci1.com/support](http://lci1.com/support) or by using the LippertNOW app. Replacement kits can be ordered from <https://store.lci1.com/> or by using the LippertNOW app.

The LippertNOW app is available for free on Apple App Store® for iPhone® and iPad® and also on Google Play™ for Android™ users.

App Store® and iPad® are registered trademarks of Apple Inc. Google Play™ and Android™ are trademarks of Google Inc.

## Safety Information

Warning, Caution and Danger symbols indicate that an installation procedure has a safety risk involved and may cause death, serious injury or property damage if not performed safely and within the parameters set forth in this manual.

**⚠ CAUTION**

**MOVING PARTS CAN PINCH, CRUSH OR CUT. KEEP CLEAR AND USE CAUTION.**

Power awnings that contain springs use tension for ease of operation and can be harmful to the end user should the stored tension come unbound. Cotter pins are installed and **MUST** be used to contain the tension when the system is being serviced.

**⚠ WARNING**

**FAILURE TO USE THE INSTALLED SAFETY FEATURES MAY RESULT IN DEATH, SERIOUS INJURY, DAMAGE TO THE UNIT AND/OR VOIDING A WARRANTY.**

## Parts List

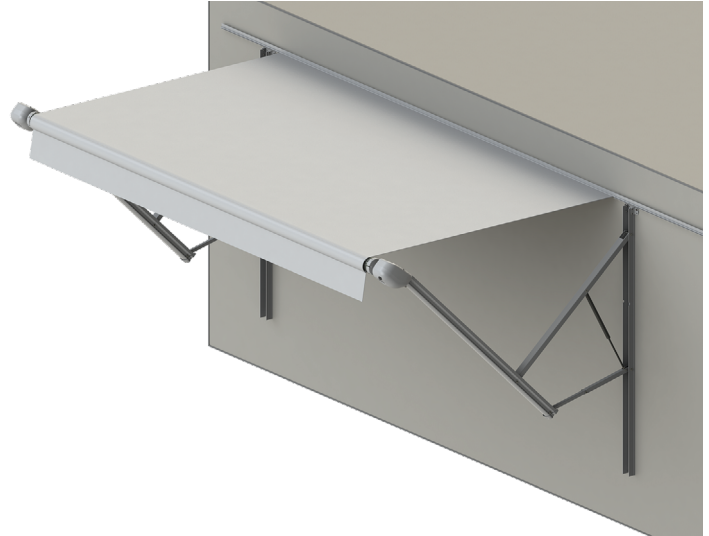

Universal Kit #	Description
<a href="#">434723</a>	Solera Power 12V 69" Kit, Black
<a href="#">434724</a>	Solera Power 12V 69" Kit, White

- Solera 12V Tall Arm (69") Flat Adjustable Pitch Arms require:
- 69" of unobstructed area from the awning rail straight down.
  - Minimum clearance of 4" between the awning rail and the top of the entry door.



## Solera® Universal Hardware

### Power Awning to Solera 12V Power Awning (For Aftermarket Application)

## Preparation

### Resources Required

- Additional Qualified Assistants
- Cordless or Electric Drill or Screw Gun
- Appropriate Drive and Drill Bits
- Socket Wrench
- 7/16" Socket
- Rivet Gun
- Locking Pliers
- Chop Saw
- Cordless Battery
- Wire Stripper
- Wire Crimper
- Ladder
- Silicone Sealant
- Non-permanent Method of Marking

## Conversion

### Dometic Power Awning to Solera® 12V Power Awning

**NOTE:** Click the following link to see the video on this conversion procedure: <https://youtu.be/n50vm-lelAg>

**NOTE:** All screws supporting the awning assembly **MUST** have a backer within the structure of the wall of the unit. Refer to the unit manufacturer for proper location.

**NOTE:** This manual will refer to the “drive side” and “idler side” throughout for various instructions. The “drive side” is the right hand side of the awning when facing the awning from the exterior of the unit. The “idler side” is the left hand side of the awning when facing the awning from the exterior of the unit.

1. Using a non-permanent method of marking, draw a vertical line along the inside of both the drive and idler side support arm assemblies. This will act as a guideline for re-installation.
2. With the awning fully extended, remove the 2 screws securing the awning fabric to the awning rail.
3. If equipped, remove drip cap from the end of the awning rail on the end of the unit that the awning assembly will be removed from.
4. If equipped, remove the wire covers from the mount arms.
5. Remove all fasteners from the lower and middle sections of both the drive and idler mount arms.  
**NOTE:** Do **NOT** remove the upper fasteners of the mount arms at this time.
6. With the power disconnected, pull the wiring out of the sidewall and disconnect all leads from the unit wires.  
**NOTE:** Be sure to check both drive and idler arms for wiring to be disconnected.
7. Connect the motor leads to a cordless battery and retract the awning so that approximately 12” of awning fabric remains extended.



## Solera® Universal Hardware

### Power Awning to Solera 12V Power Awning (For Aftermarket Application)

8. For both the drive and idler side support arm assemblies, secure the outer arm to the mount arm using the nylon ties provided.

### **⚠ WARNING**

**IF NOT PROPERLY SECURED, THE SUPPORT ARMS CAN KICK OUT DUE TO PRESSURE FROM THE GAS STRUT, WHICH MAY RESULT IN SERIOUS INJURY OR PROPERTY DAMAGE.**

9. With additional assistants holding the support arm assemblies, remove the upper fasteners from both the drive and idler mount arms. Pull the nylon ties tight.

10. Carefully slide the entire awning assembly along the awning rail until the polycord clears the channel.

11. Place the awning assembly on a clean, level surface that is free of any debris that might scratch or damage the roll tube or fabric.

**NOTE:** Contact Dometic before installation to verify the version of awning to be converted. Newer versions may not need spring pins inserted into the tube to later release tension.

12. On the idler support arm assembly, insert a cotter pin into the end cap to lock the spring head in place.

13. On the drive support arm assembly, drill out the rivets securing the end cap to the roll tube.

14. Completely detach the support arm assembly and internal motor from the roll tube.

### **⚠ WARNING**

**THE SPRING IS UNDER EXTREME TENSION. IMPROPER HANDLING COULD CAUSE DEATH, SERIOUS INJURY OR PROPERTY DAMAGE.**

15. Using a  $\frac{7}{16}$ " socket, remove the bolt securing the idler head to the support arm assembly and detach the head from the support arm assembly.

16. With a firm grip on the roll tube and the idler head firmly secured with locking pliers, remove the cotter pin from the end cap.

**NOTE:** Padding the locking pliers will prevent the scratching of components.

17. Carefully release the tension by slowly unwinding the spring head.

18. Drill out the rivets securing the end cap to the roll tube.

19. Completely detach the idler end cap and spring assembly from the roll tube.

20. Unroll the fabric. Still working on the idler side of the roll tube, slide the fabric towards the drive side of the roll tube so it is well out of way.

21. Using the tape provided, align one edge of the tape with the edge of the roll tube and wrap the tape around the roll tube.

**NOTE:** This provides the guideline for cutting the roll tube. Click the link to see the video on this procedure: <https://youtu.be/n50vm-lelAg>.

22. Using a chop saw, cut the roll tube along the edge of the tape applied in the previous step.

**NOTE:** Sharp edges and/or burrs **MUST** be filed down.

23. Secure both drive and idler Solera end caps to the roll tube with the provided rivets.

**NOTE:** It may be necessary to drill out the previous holes in order to accommodate the larger-sized rivets.

24. Center the fabric on the roll tube and secure each end by installing the provided  $\frac{1}{4}$ " pan head screw through the polycord into the roll tube.

25. Re-roll the fabric after it is centered and cut off the extra polycord.

26. Insert the shaft of the Solera idler head assembly into the end cap. Align the holes and secure with the provided #8 - 32 x  $\frac{1}{2}$ " wax screw.

27. Insert the shaft of the Solera drive head assembly into the end cap. Align the holes and secure with the provided #8 - 32 x  $\frac{1}{2}$ " wax screw.

**NOTE:** Keep the head of the wax screw  $\frac{1}{8}$ " from fastened to avoid compromising the structural integrity of the wax screw.



## Solera® Universal Hardware Power Awning to Solera 12V Power Awning (For Aftermarket Application)

**28.** With additional assistants holding the support arm assemblies, insert the polycord into the awning rail channel and slide the Solera awning assembly along the awning rail.

**29.** Place the drive side support arm assembly directly under the awning rail so the top of the mount arm is touching the bottom of the rail.

**NOTE:** Support arm should be installed so that it covers holes of the original awning, but no lower than 3" below the awning rail. Seal old holes with sealant.

**30.** Align the drive side support arm assembly to cover the holes on the unit at the bottom of the arm. Make sure the assembly is parallel with the corresponding guideline marked in Step 1.

**NOTE:** There may still be a hole showing at the top of the arm due to the width of the angle brackets.

**31.** Secure the upper section of the mount arm to the unit with 2 of the provided #14 x 1 ¼" screws.

**NOTE:** Silicone sealant **MUST** be used on all screws and holes to prevent water from infiltrating the unit.

**32.** Repeat Steps 29-31 for the idler side support arm assembly.

**33.** Cut the nylon ties containing the support arm assemblies.

**34.** At the drive side support arm assembly, connect the motor leads to a cordless battery and fully extend the awning.

**35.** Remove the wire covers to expose the lower and middle sections of the mount arm.

**NOTE:** If the power leads exiting the unit do not align with the hole in the wall mount arm, a new hole must be drilled out on the wall mount arm **PRIOR** to securing the lower and middle sections of the arm so as not to damage the unit.

**36.** Secure the lower and middle sections of the drive side mount arm to the unit with the provided #14 x 1 ¼" screws or rivets. Make sure the arms are square on the wall of the unit. (There will be 2 screws in the lower holes and 2 screws in the middle holes.)

**NOTE:** For units with fiberglass sidewalls, Lippert requires the use of rivets for securing the lower and middle sections of the mount arm.

**37.** Repeat Steps 35-36 for the idler side mount arm.

**NOTE:** Before proceeding, see the **Wiring** section to complete installation.

**38.** Extend and retract the awning several times to ensure that the fabric is square on the roll tube. Secure the fabric in the awning rail no more than 1" inside the edge of the fabric on both ends using a #6 x ½" hex head screw. Install the screw down through the awning rail into the fabric and the polycord.

**39.** If previously equipped, reinstall drip caps.

### Carefree Power Awning to Solera® 12V Power Awning

**NOTE:** All screws supporting the awning assembly **MUST** have a backer within the structure of the wall of the unit. Refer to the unit manufacturer for proper location.

**NOTE:** This manual will refer to the "drive side" and "idler side" throughout for various instructions. The "drive side" is the right hand side of the awning when facing the awning from the exterior of the unit. The "idler side" is the left hand side of the awning when facing the awning from the exterior of the unit.



**Fig.1**

**1.** Using a non-permanent method of marking, draw a vertical line along the inside of both the drive side and

# Solera® Universal Hardware

## Power Awning to Solera 12V Power Awning

(For Aftermarket Application)

idler side support arm assemblies. This will act as a guideline for re-installation (Fig.1).

2. With the awning fully extended, remove the wire covers, if equipped, from the mount arms.



Fig.2

3. Remove all fasteners from the lower and middle sections of both the drive side and idler side mount arms (Fig.2).

**NOTE:** Do **NOT** remove the upper fasteners of the mount arms at this time.

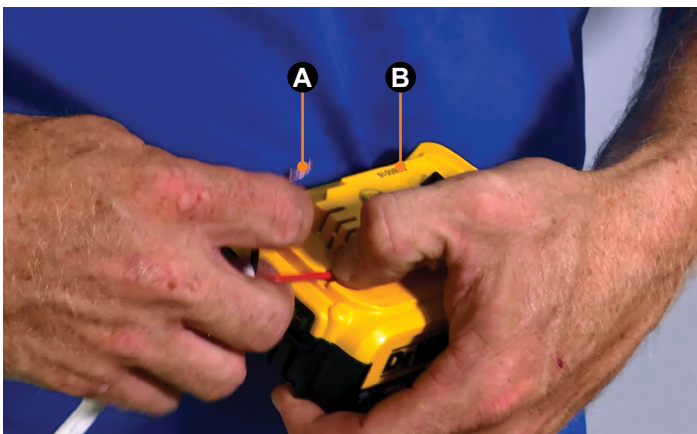

Fig.3

4. Pull the wiring out of the sidewall and disconnect all leads from the unit wires.

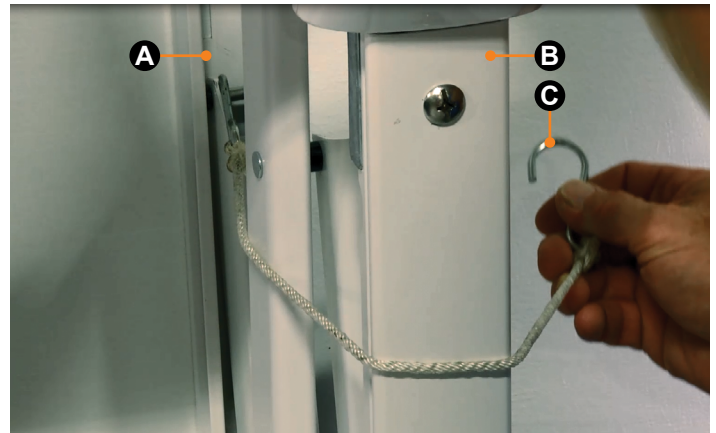

Fig.4

### **⚠ WARNING**

**IF NOT PROPERLY SECURED, THE SUPPORT ARMS CAN KICK OUT DUE TO PRESSURE FROM THE GAS STRUT, WHICH MAY RESULT IN SERIOUS INJURY OR PROPERTY DAMAGE.**

5. Connect motor leads (Fig.3A) to a cordless battery (Fig.3B) and retract the awning so that approximately 12" of awning fabric remains extended.

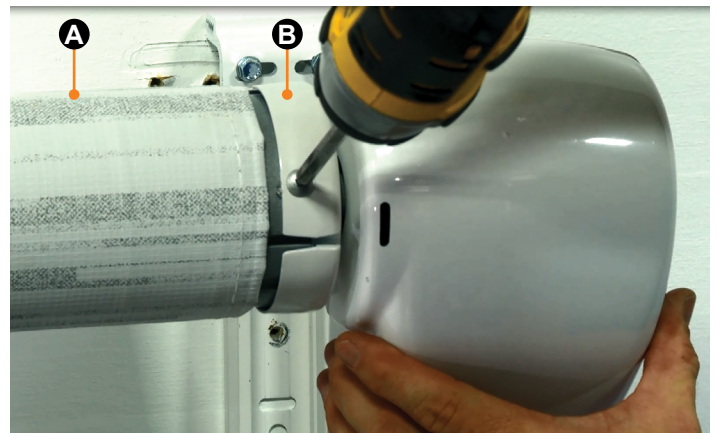

Fig.5



## Solera® Universal Hardware Power Awning to Solera 12V Power Awning (For Aftermarket Application)

6. For both the drive side and idler side support arm assemblies, secure the outer arm (**Fig.4B**) to the mount arm (**Fig.4A**) using the nylon ties provided (**Fig.4C**).



**Fig.6**

7. On the drive side support arm assembly and with an additional assistant holding the roll tube (**Fig.5A**), remove the screws securing the end cap (**Fig.5B**) to the roll tube.

8. With additional assistants holding the support arm assembly, remove the upper fasteners from the drive side

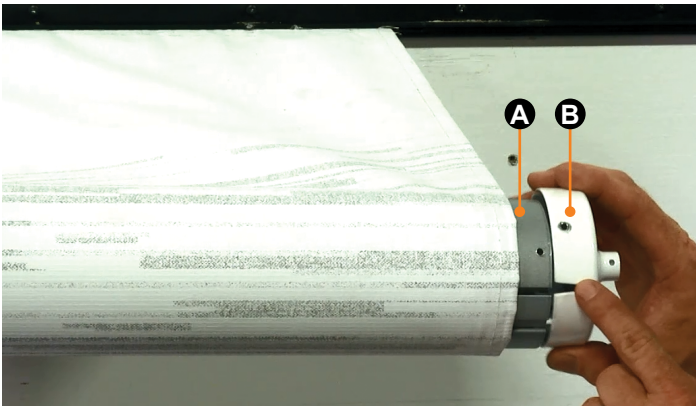

**Fig.7**

mount arm (**Fig.6**). Pull the nylon ties tight.

9. Detach the drive side support arm assembly from the unit and roll tube and set aside.

10. Place the Solera end cap (**Fig.7B**) on the end of the roll tube (**Fig.7A**), making sure it is properly seated and the roll tube channel is aligned with the channel on the end cap.

11. Secure the Solera end cap to the roll tube with the provided rivets.

**NOTE:** It may be necessary to drill out the previous holes

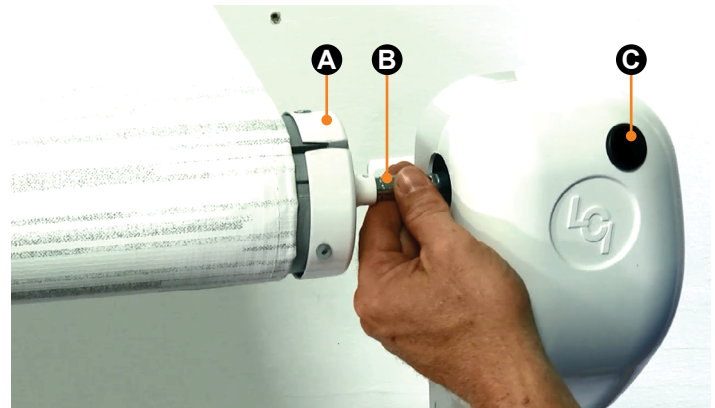

**Fig.8**

in order to accommodate the larger-sized rivets.

12. Insert the Solera drive head assembly shaft (**Fig.8B**) into the end cap (**Fig.8A**).

**NOTE:** When determining the drive head assembly from



**Fig.9**

the idler head assembly, the drive head assembly will have an override plug (**Fig.8C**), whereas the idler head assembly will not.

13. Align the holes and secure with the provided #8 - 32 x 1/2" wax screw (**Fig.9**).



## Solera® Universal Hardware Power Awning to Solera 12V Power Awning (For Aftermarket Application)

**NOTE:** Keep the head of the wax screw  $\frac{1}{8}$ " from fastened to avoid compromising the structural integrity of the wax screw.

**14.** Place the drive side support arm assembly directly under the awning rail so the top of the mount arm is touching the bottom of the rail.

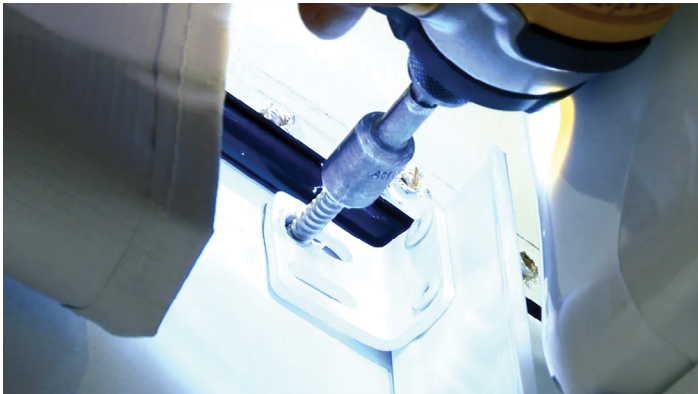

**Fig.10**

**NOTE:** Support arm should be installed so that it covers holes of the original awning, but no lower than 3" below the awning rail. Seal old holes with sealant.

**15.** Align the drive side support arm assembly with the corresponding guideline marked in Step 1, being sure all previous holes are covered.

**16.** Secure the upper section of the drive side mount arm to the unit with 2 of the provided #14 x  $1\frac{1}{4}$ " screws (**Fig.10**).

**NOTE:** Silicone sealant **MUST** be used on all screws and holes to prevent water from infiltrating the unit.

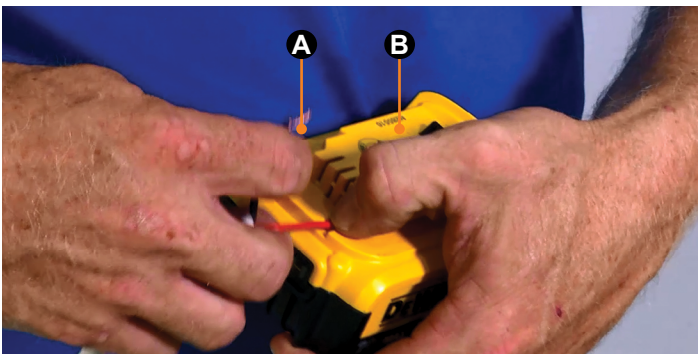

**Fig.11**

**NOTE:** Do **NOT** install fasteners to the lower and middle sections of the wall mount arm at this time.

**17.** Repeat Steps 7-16 for the idler side support arm assembly.

**18.** Cut the nylon ties containing the support arm assemblies.

**19.** At the drive side support arm assembly, connect the motor leads (**Fig.11A**) to a cordless battery (**Fig.11B**) and fully extend the awning.

**20.** Remove the wire covers to expose the lower and middle sections of the mount arm.

**NOTE:** If the power leads exiting the unit do not align with the hole in the wall mount arm, a new hole must be drilled out on the wall mount arm **PRIOR** to securing the lower and middle sections of the arm so as not to damage the unit.

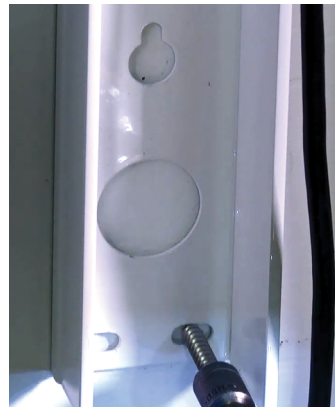

**Fig.12**

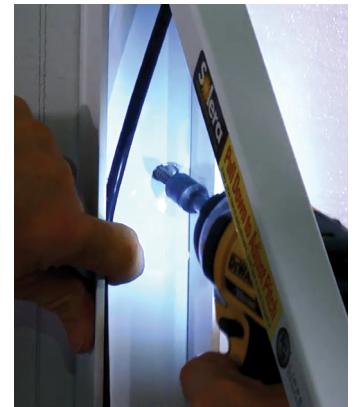

**Fig.13**

**21.** Secure the lower (**Fig.12**) and middle (**Fig.13**) sections of the drive side mount arm to the unit using the provided #14 x  $1\frac{1}{4}$ " screws or rivets. (There will be 2 screws in the lower holes and 2 in the middle holes).

**NOTE:** Silicone sealant **MUST** be used on all screws and holes to prevent water from infiltrating the unit.

**NOTE:** For units with fiberglass sidewalls, Lippert requires the use of rivets for securing the lower and middle sections of the mount arm.

**22.** Repeat Steps 20-21 for the idler side mount arm.

**NOTE:** See "Wiring" Section to complete installation.

**23.** Replace wire covers after wiring is complete.





## Solera® Universal Hardware Power Awning to Solera 12V Power Awning (For Aftermarket Application)

### Wiring

1. Pull the wires from the unit through the support arm assembly. These wires may be located at the bottom or the top of the support arm assembly

2. Connect wiring from the unit to the switch and the awning drive head per the wiring diagram below (Fig.14).

**NOTE:** Check the switch. If the awning is running in reverse of what the switch indicates, reverse the wires.

**NOTE:** Solera Power Awning motors come stock with an internal 6A auto reset breaker. If this breaker trips, it will take approximately 30 seconds to reset. Lippert recommends that the awning be wired into a 15A circuit.

**NOTE:** All wire to be 14 AWG or larger as necessary to provide 12V minimum at all times at the connection to the LCI-supplied power cable.

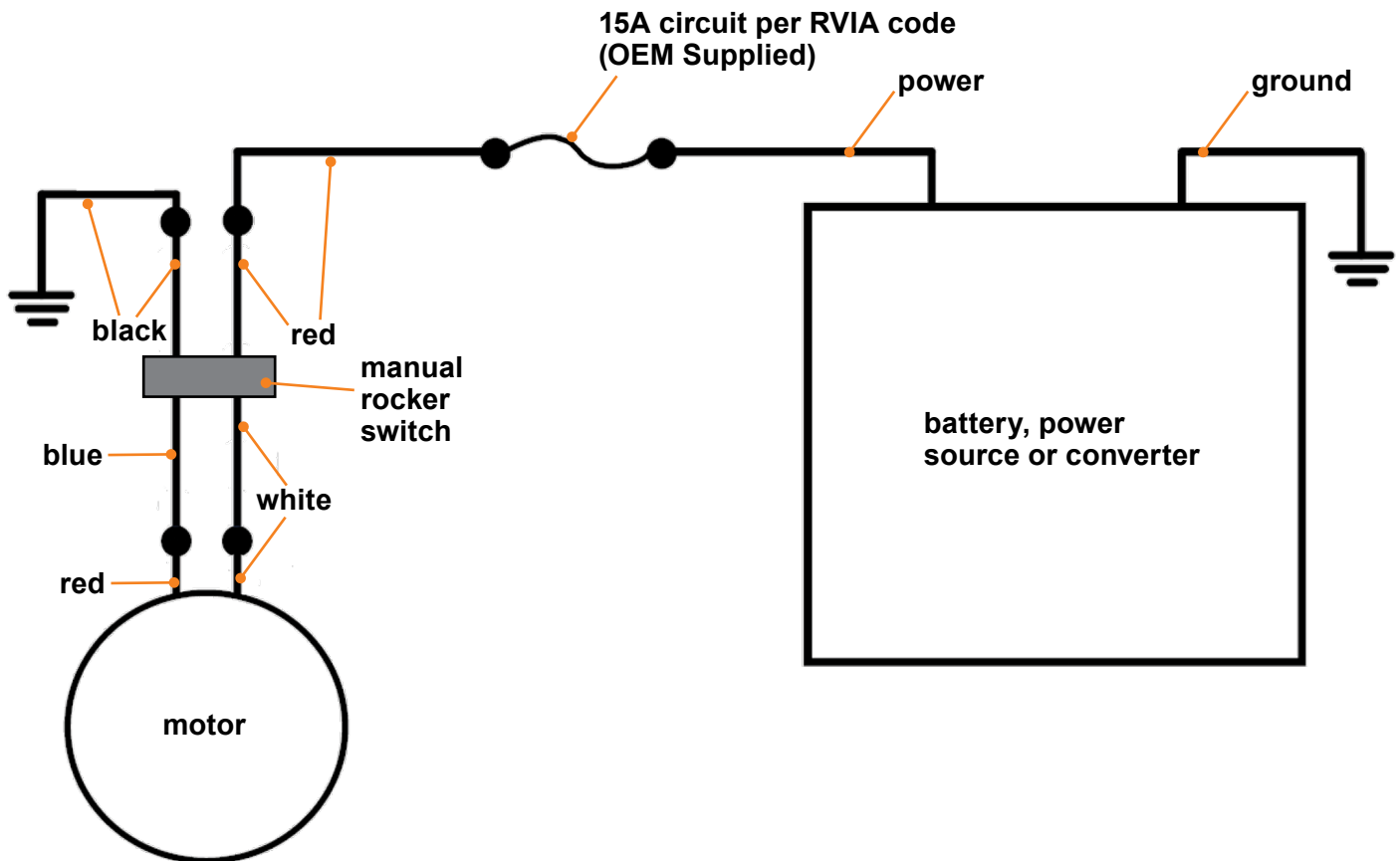

Fig.14

## Operation

### Extending the Awning

1. Verify the unit's battery is fully charged and connected to the electrical system.
2. Press and hold **EXTEND (Fig.15A)** until the awning is extended completely.

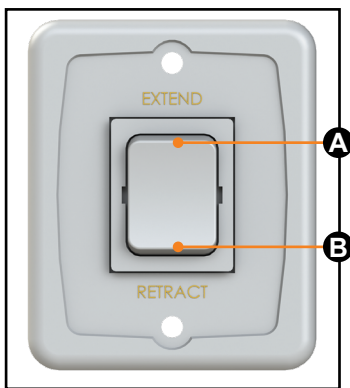

Fig.15

**NOTE:** The awning fabric should always be above the roll tube. However, if the extend switch is engaged too long or extend is hit inadvertently instead of retract, the awning will roll up backward. This is not a defect. To correct the fabric orientation, press the **RETRACT (Fig.15B)**. The awning will then extend to its correct orientation and normal operation can resume.

## ⚠ CAUTION

**TYING DOWN THE ROLL TUBE ONCE THE AWNING IS EXTENDED WILL NOT ALLOW THE FREE-FLOATING SUPPORT ARMS TO WORK AS DESIGNED AND MAY CAUSE DAMAGE TO THE AWNING OR UNIT.**

### Retracting the Awning

1. Verify the unit's battery is fully charged and connected to the electrical system.

**NOTE:** The awning can be retracted without resetting the pitch.

2. Press and hold **RETRACT (Fig.15B)** until the awning is retracted completely.

### Adjusting Pitch

**NOTE:** The awning will pitch itself to purge the pooling of excess water and may dump a significant amount of water without notice.

**NOTE:** Pitch can be set by adjusting the pitch arm to tip one side of the awning to allow water runoff.

1. Extend the awning to the fully open position.
2. Choose the side of the awning for optimum shade or convenient water runoff. Pull downward on the joint of the pitch arm until desired pitch is set (**Fig. 16A**). Belleville washers and bolt (**Fig. 16B**) allow for the joint to remain in the position set by the operator.

**NOTE:** Some awnings are equipped with a 2-position pitch arm (**Fig.17**). The 2-position arm can be set in the pitch position or snapped into a straight position by pushing the release button (**Fig.17A**) and sliding the sleeve (**Fig.17B**).

**NOTE:** Do not push the joint of the pitch arm up past the point where the two sections are in a straight line. This will put tension on the gas strut, which can cause the strut to break.

**NOTE:** The awning can be retracted without resetting the pitch.

**NOTE:** If the pitch arm does not hold position, it can be tightened by adjusting the bolt (**Fig.16B**) in the center of the joint.

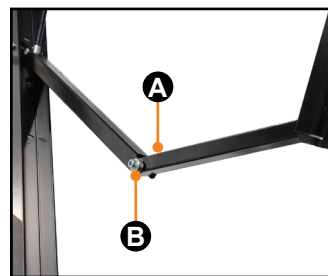

Fig.16

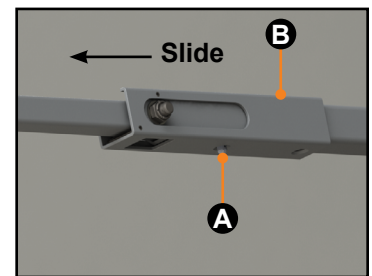

Fig.17

# Troubleshooting Chart

What Is Happening?	What Should Be Done?
Awning won't open or close.	If optional travel locks are installed, ensure that they have been unlocked.
	Verify the fuse is good.
	Check for power at the motor when the switch is in the extended or retracted position.
Awning pitch won't stay in the flat position.	Check for bad gas strut.
	Check pitch arm bolt for proper tension. (High winds can cause the pitch arm to deviate from the flat position due to the built-in safety feature of the awning.)
	Make sure all 3 washers are in the proper location of the pitch arm.
Awning doesn't close all the way.	The awning is considered completely closed as long as the outer arm is overlapping the mount arm. This overlap can vary
	Ensure there are no obstructions in the support arm assemblies preventing the awning from closing.
	Verify the fabric is square from unit to roll tube and is rolling up straight on the roll tube.
Awning runs slowly.	The awning will run slower during retract than extend. Retract is approximately 35 seconds while extend is approximately 27 seconds on a fully-charged battery.
	Ensure there are 12 volts where the unit wire meets the awning wire during retract.
	Ensure the pitch arms are not bent in an upward direction.
	Ensure the ground wire before the switch has a good connection to the battery or chassis.
Lights won't work.	There is a resettable fuse that can take up to 30 seconds to reset.
	Make sure to have 12 volts to the red wire on the light.
Awning seems to wobble when extending or retracting.	Ensure the bolts that hold the head to the support arm assemblies are tight.
	Ensure the end caps are seated properly on the roll tube.
	Ensure the shaft coming out of the head going to the end cap isn't bent
	Ensure the mount arms are properly secured to the wall.
	Ensure no part of the support arm assemblies are bent.
Awning works in opposite direction of what switch shows.	Wires going to awning have been reversed or switched. Reverse the wires.
Awning Rolls Up Backward	The awning fabric should always be above the roll tube. However, if the crank handle is operated past full extension, the awning will roll up backwards. This is not a defect. To correct the fabric orientation, simply operate the crank handle in the retract direction and the awning will then extend to its correct orientation and normal operation can resume.



## Solera® Universal Hardware Power Awning to Solera 12V Power Awning (For Aftermarket Application)

## Troubleshooting

### Manual Override

In the event of power loss or motor failure, the awning can be extended and retracted manually. Perform the following procedure to manually retract the awning.

**NOTE:** This procedure may also be performed to extend or retract the awning in the event of dry camping or camping without a battery.

1. Remove the rubber grommet (**Fig.18A**) from the drive head assembly, exposing the manual override nut on the motor.

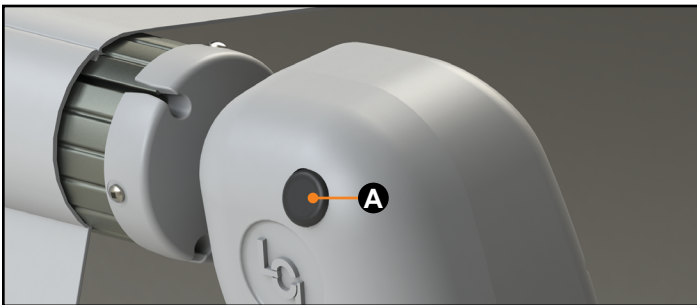

**Fig.18**

2. Using a  $\frac{7}{16}$ " socket and cordless or electric drill or screw gun, spin the manual override nut counterclockwise to retract the awning (**Fig.19**).



**Fig.19**

**NOTE:** Use caution when retracting the awning manually. The use of a step stool or ladder may be required to completely retract the awning.

3. When the awning is completely retracted, replace the rubber grommet in the drive head assembly (**Fig.18A**).

**NOTE:** The motor's internal drive system prevents the awning from moving (extend or retract) on its own. If the motor is damaged or disabled, be sure to secure the awning in the retracted position with a strap around both the outer arm and the mount arm before the manual override nut is released.

## ⚠ CAUTION

**DURING INCIDENTS OF HIGH WIND, HEAVY RAIN OR EXTENDED TIME AWAY FROM THE UNIT, IT IS ADVISABLE TO RETRACT THE AWNING COMPLETELY TO PREVENT DAMAGE TO THE AWNING AND THE UNIT.**

## Maintenance

### Fabric Care

**NOTE:** If the awning is retracted while wet, extend the awning and let it dry as soon as conditions allow before retracting. This will help prevent the formation of mildew and add greatly to the life of the awning. Mildew does not form on the fabric itself, but on the accumulated dust, dirt and grime.

**NOTE:** Periodically clean vinyl or woven acrylic fabric using a mixture of  $\frac{1}{4}$  cup of dish soap and 5 gallons of warm water. Liberally apply the mixture on the top of the fabric and retract the awning for 5 minutes. This will apply the mixture to the bottom of the fabric as well. Extend the awning and hose off with fresh water. Repeat if necessary. Allow to dry before retracting.



Manual information may be distributed as a complete document only, unless Lippert provides explicit consent to distribute individual parts.

All manual information is subject to change without notice. Revised editions will be available for free download at [lippert.com](http://lippert.com). Manual information is considered factual until made obsolete by a revised version.

Please recycle all obsolete materials and contact Lippert with concerns or questions.