

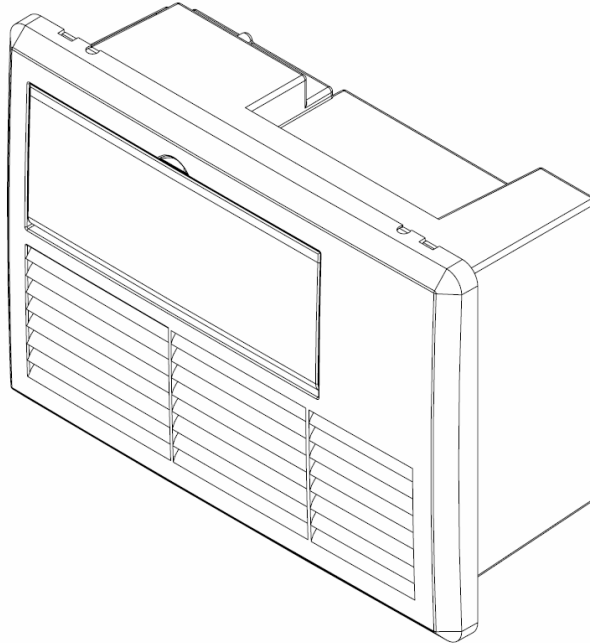

# Installation and Operation Guide for PD4100 Series Power Control Centers

Extended warranties  
are available for purchase at  
[www.progressivedyn.com](http://www.progressivedyn.com)



Thank you for selecting Progressive Dynamics as your choice for your RV power needs. We'd like to welcome you to a full line of industry leading and time tested products including our newest addition to the PDI family, the PD4100 Series POWER CONTROL CENTER.

The PD4100 Series POWER CONTROL CENTERS offer break-through technologies that help maintain and lengthen the life of your batteries such as our patented Charge Wizard®.

The heart of the PD4100 is the INTELI-POWER Converter. The built-in Charge Wizard® microprocessor constantly monitors the battery voltage then automatically adjusts the converter output voltage to provide the proper charging voltage for fast recharges and long-term maintenance.

*The intelligent way to charge and maintain your RV battery.*

With enough AC and DC branches you'll have plenty of options for your growing RV needs.

**Progressive Dynamics, Inc.**

507 Industrial Rd.

Marshall, MI 49068

[www.progressivedyn.com](http://www.progressivedyn.com)

Patent Numbers: 5,687,066 - 5,600,550 - 5,982,643 - 6,184,649 - 7,782,002

## Table of Contents

<b>Installation Instructions</b>	<b>1</b>
<b>Wiring Diagram</b>	<b>1</b>
<b>Features and Operating Instructions</b>	<b>2</b>
<b>The Charge Wizard</b>	<b>2</b>
<b>Reverse Battery Protection</b>	<b>2</b>
<b>Specs and Troubleshooting</b>	<b>3-5</b>

### ***LIMITED WARRANTY***

- I. **LIMITED WARRANTY:** Progressive Dynamics, Inc. warrants its power control center to be free from defects in material or workmanship under normal use and service; and limits the remedies to repair or replacement.
- II. **DURATION:** This warranty shall extend for a period of two years from the original date of purchase, and is valid only within the continental limits of the United States and Canada.
- III. **WARRANTY EXCLUSIONS:** This warranty specifically does not apply to:
  - A. Any product which has been repaired or altered in any way by an unauthorized person or service station;
  - B. Damage caused by excessive input voltage, misuse, negligence or accident; or an external force;
  - C. Any product which has been connected, installed or adjusted or used other than in accordance with the instructions furnished, or has had the serial number altered, defaced or removed;
  - D. Cost of all services performed in removing and reinstalling the power converter; and
  - E. ANY LOST PROFITS, LOST SAVINGS, LOSS OF USE OF ENJOYMENT OR OTHER INCIDENTAL DAMAGES ARISING OUT OF THE USE OF, OR INABILITY TO USE, THE PRODUCT. THIS INCLUDES DAMAGES TO PROPERTY AND, TO THE EXTENT PERMITTED BY LAW, DAMAGES FOR PERSONAL INJURY. THIS WARRANTY IS IN LIEU OF ALL OTHER WARRANTIES, INCLUDING IMPLIED WARRANTIES OF MERCHANTABILITY AND FITNESS FOR A PARTICULAR PURPOSE.
- IV. **PROOF OF PURCHASE:** A warranty claim must be accompanied by proof of the date of purchase.
- V. **CLAIM PROCEDURE:** Upon discovery of any defect, Progressive Dynamics, Inc. shall be supplied the following information at the address listed below:
  - A. Name and address of the claimant;
  - B. Name and model of the product;
  - C. Name, year and model of the recreational vehicle in which the product was installed;
  - D. Date of purchase; and
  - E. Complete description of the claimed defect.

Upon determination that a warranty claim exists (a defect in material or workmanship occurring under normal use and service,) the converter section shall be shipped postage prepaid to Progressive Dynamics, Inc. together with proof of purchase. The product will be repaired or replaced and returned postage prepaid.

Mail to: Progressive Dynamics, Inc.  
507 Industrial Road  
Marshall, MI 49068

**For Warranty Service Call: (269) 781-4242**

# Installation Instructions

The PD4100 series POWER CONTROL CENTERS should be installed horizontally (converter section to the right). Unit is NOT ignition protected. Do not mount in the LP gas or the battery compartment. The POWER CONTROL CENTER is not designed for wet or damp locations. Install in an interior / dry location. The INTELI-POWER converters are not designed for zero clearance compartments. Cut mounting hole to approximately 6 7/8" x 10 1/8". Connect wiring system using appropriately sized cable clamp.

Connect battery POS (+) to the black BATTERY POS. (+) wire and battery NEG (-) to the white BATTERY NEG. (-) wire. Connect branch circuit wiring as necessary. (see wiring diagram for component details)

The OEM should test the POWER CONTROL CENTER converter under full load conditions in its intended mounting location to ensure proper ventilation. A minimum compartment size of 3 cubic feet is recommended. Failure to provide adequate ventilation will prevent the converter from supplying full output power.

When used with a gel cell battery, install jumper (0.100" spacing, not supplied) to 2-pin connector at H4 on main circuit board.

## Detailed Wiring Diagram

Note: Some factory installed wiring not shown for clarity

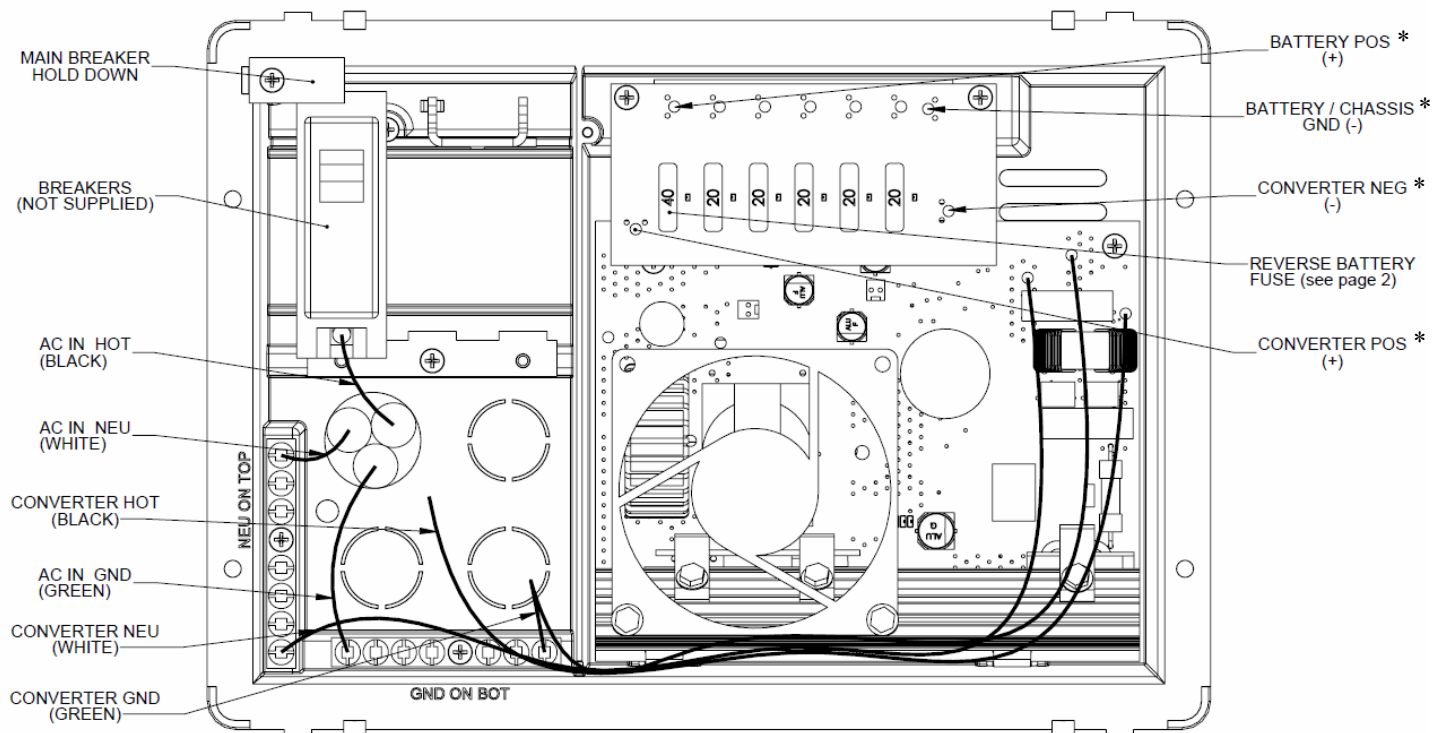

Note: Breakers and fuses are not supplied. Connect Converter Hot to an open breaker.  
 Note: Above image may vary, depending on model.

\* - Wiring on back side of circuit board

**Consult a licensed electrician or an RV technician for installation assistance**

**User Information**

Many options will be installed prior to the purchase of your new RV, however there are a few options that you should be aware of while operating your new POWER CONTROL CENTER.

The Charge Wizard selects the best mode for your battery automatically. The Charge Wizard will be able to select between three very unique modes of battery charging. BOOST, NORMAL, and STORAGE.

**BOOST MODE:** If the converter senses that the battery voltage has dropped below a preset level the output voltage is increased to approximately 14.4 volts DC to rapidly recharge the battery.

**NORMAL MODE:** Output voltage set at approximately 13.6 volts DC.

**STORAGE MODE:** When the converter senses that there has been no significant battery usage for 30 hours the output voltage is reduced to 13.2 volts DC for minimal water usage. When in storage mode the microprocessor automatically increases the output voltage to 14.4 volts DC for 15 minutes every 21 hours to help reduce sulfation of the battery plates.

- All times and voltages provided above are approximate. -

**CAUTION**

IT IS IMPORTANT THAT THE FLUID LEVEL OF ANY CONNECTED BATTERIES BE CHECKED ON A REGULAR BASIS. LEAD/ACID BATTERIES WILL “GAS” AND LOSE SOME FLUID WHEN CONTINUOUSLY CONNECTED TO ANY CHARGING SOURCE.

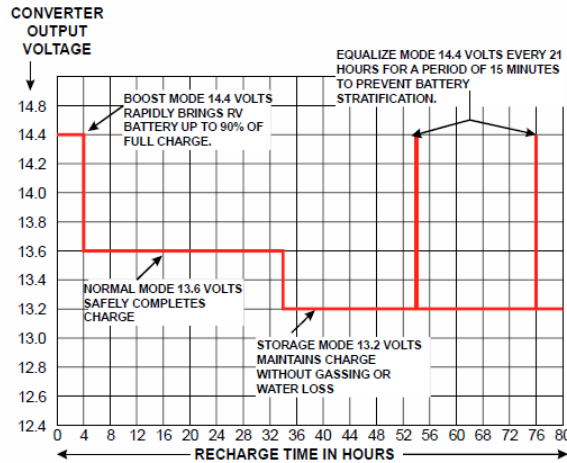

**REVERSE BATTERY PROTECTION CIRCUIT**

If a battery is accidentally hooked up backwards, the converter will be protected. An easily accessible ATC type fuse will blow when a battery is connected in reverse. Replace with same type and rating.

Amp/Model	# of fuses	Fuse size (amps)
35	1	40

**The DC Section:**

The DC panel features 6 branch positions rated up to 30A for accessories. Each branch has an LED to indicate which fuse has blown. See product labeling for actual DC fuse position ratings.

**CAUTION**

FOR CONTINUED PROTECTION AGAINST RISK OF FIRE OR ELECTRICAL SHOCK, REPLACE ONLY WITH SAME TYPE AND RATING FUSE.

<b>Specifications</b> (Specifications subject to change without notice)	
<b>Model</b>	PD4135
<b>AC Section</b> (PD4100)	240/120 VAC 30A Maximum Input 120 VAC 30A Maximum Output - 6 Branch Circuits Max.*
<b>DC Section</b>	12 VDC 35A Max.
<b>Converter Section</b>	Input: 105-130 VAC 50/60 Hz 725 Watts Output: 13.6 VDC, 35 Amps Weight: 6 lbs

\* Consult local regulatory authority for possible branch circuit restrictions

**Breakers: Recommended breakers rated maximum 30A for PD4100 series**

The following breakers are suitable for MAIN and BRANCH breakers	MAIN	Branch	Filler Plate
ITE/Siemens—QP,QT			
Thomas & Betts—TB & TBBD Series			ITE/Siemens QF3
Square D—HOM, HOMT	30A	20A	GE TQLFPI
Cutler Hammer/Bryant—BR, BRD Series			
GE—HACR			

**TROUBLE SHOOTING GUIDE**

<u>PROBLEM</u>	<u>POSSIBLE CAUSES</u>	<u>ACTION</u>
No Output	120 VAC supply not connected	Connect power supply Check AC distribution panel for proper operation
	Reverse battery fuses blown (See page 1 for location)	Check for reverse battery connection. Replace fuses with same type and rating (See page 2)
	Short circuit	Trace RV circuits for possible fault
	Unit has shutdown due to over voltage (Converter will shut down if the input voltage exceeds 132 VAC)	Check input voltage Correct input voltage
	Low Output	Compartment gets too hot
Excessive load for converter		Reduce load requirements or install larger converter
Input voltage not between 105-130 VAC		Correct input supply voltage
Bad battery cell(s)		Replace battery
Intermittent or no Output on Generator, works on Shore Power	Unit has shutdown due to over voltage.	Add another load to the generator, this may reduce the “spikes” to an acceptable level
	Some generators exhibit excessive voltage spikes on the AC power output, this may cause the over voltage protection to shut the unit down	Contact generator manufacturer for possible defect in the generator
Open Fuse Indicator lit (See page 1 for location)	Fuse open.	Replace fuse with same type and rating.

**Consult a licensed electrician or an RV technician for installation assistance**

**Do not replace the converter section unless the following checks have been performed:**

1. Use an AC voltmeter to check for the proper voltage at the 120 VAC breaker that the converter is connected to. This voltage should be between 105 and 130 volts.
2. Remove the reverse battery fuse and check the converter output from the CONVERTER GND to the CONVERTER POS terminals on the DC board. This should be 13.6 VDC.
3. Check the Reverse Battery fuse . The fuse will only blow if the battery or DC output leads were connected in reverse, even for a moment. If it is blown check the polarity of the battery connections before replacing it.
4. If the Converter output is not present and there is AC to the converter , the converter is defective.

**SEE PAGE 5 FOR INSTRUCTIONS FOR SAFE REMOVAL OF CONVERTER SECTION.**

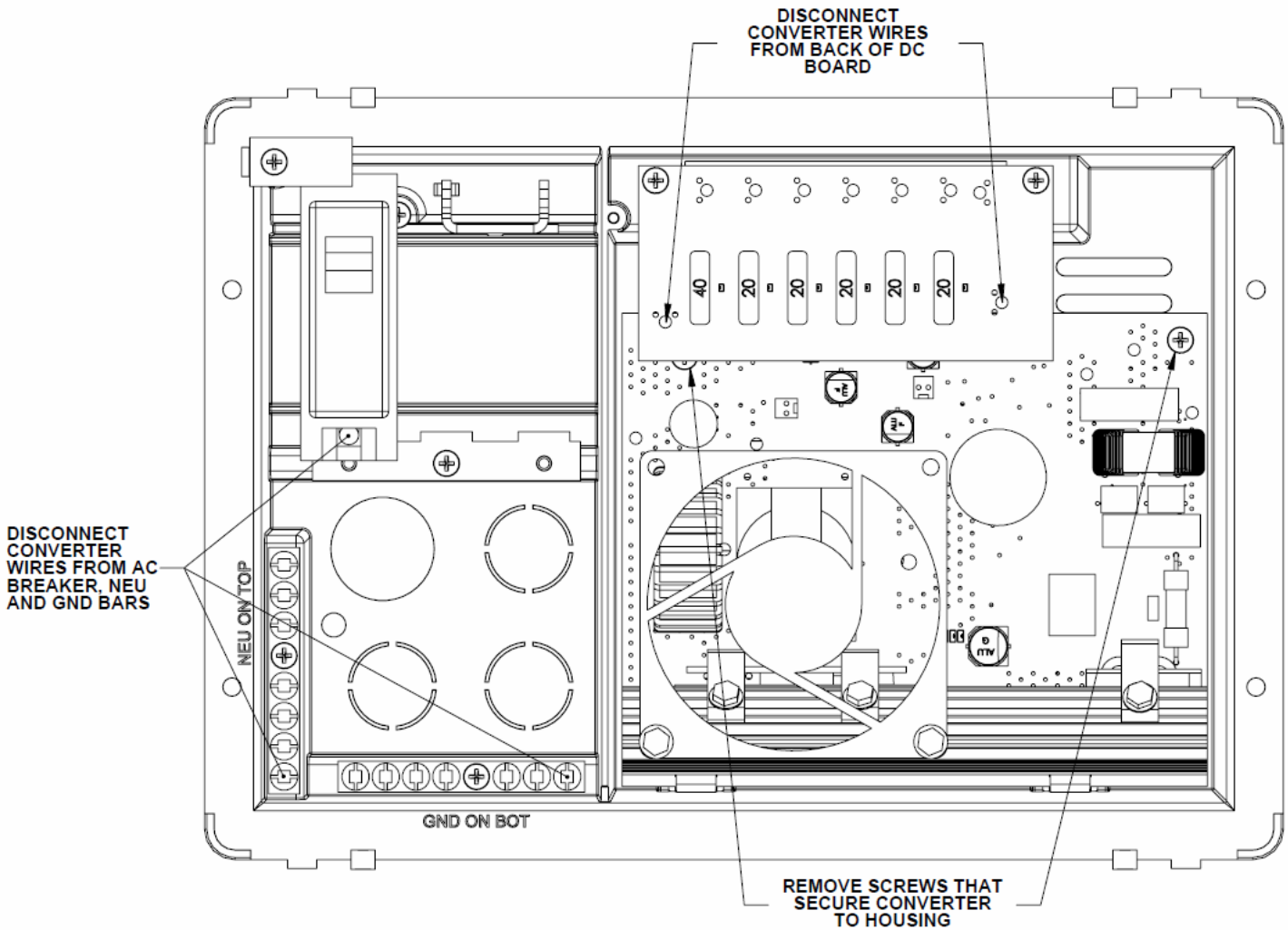

*If you should need to replace the power converter for any reason, follow these steps to safely remove the converter section.*

**WARNING: Make sure all power is disconnected before proceeding.**

1. Remove the neutral, ground, and breaker wires that lead to the converter on the AC side.
2. Remove the converter output wires from the DC side, ground and positive.
3. Finally unscrew the two screws that hold the converter section to the plastic housing.
4. Reverse steps to install new converter.

**For repairs, do not remove entire AC/DC panel. Only send the converter section.**

Make sure you use proper packaging to ensure the product's safe arrival.

### **REPLACING THE CONVERTER MODULE**

(Replace converter with the same model and rating as previous converter.)

REPLACEMENT CONVERTER SECTIONS:

Model # - PD4135CSV (35-Amp Converter Module, with built-in Charge Wizard)

**NOTES:**

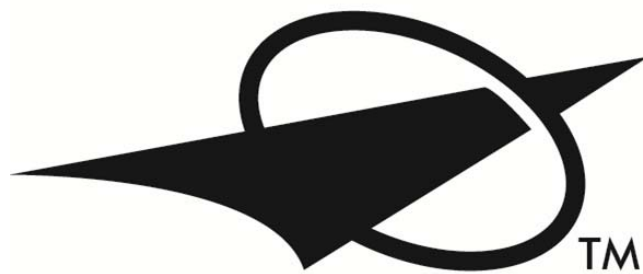

**Progressive Dynamics, Inc.**

507 Industrial Rd  
Marshall, MI 49068

Visit us on the web for other great products.

[www.progressivedyn.com](http://www.progressivedyn.com)