

True Sine Wave Inverter

Eaton 1250W / 1500W / 1800W Inverter Operation and Installation Guide

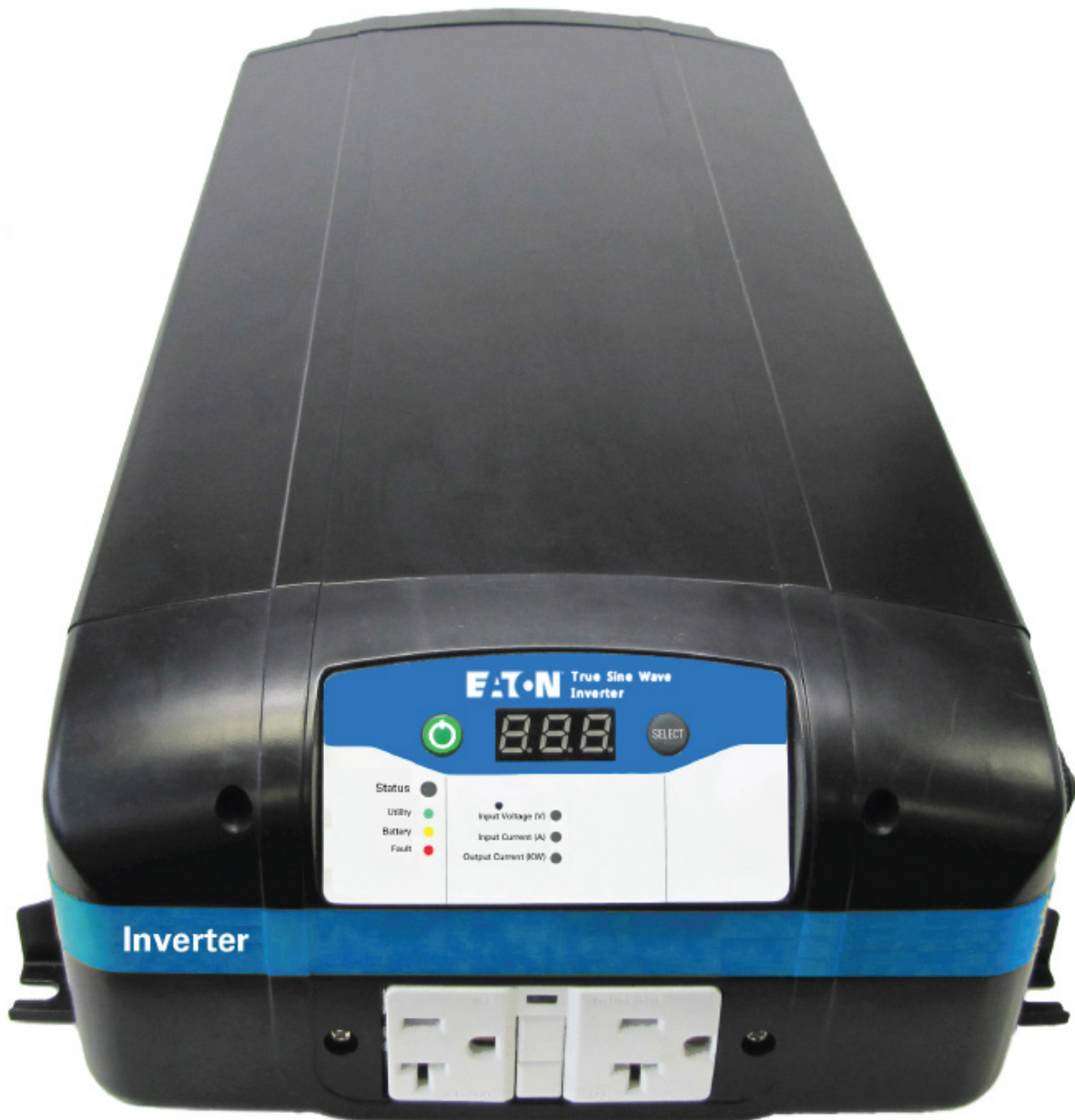

EATON

Powering Business Worldwide

DISCLAIMER OF WARRANTIES AND LIMITATION OF LIABILITY

The information, recommendations, descriptions and safety notations in this document are based on Eaton Corporation's ("Eaton") experience and judgment and may not cover all contingencies. If further information is required, an Eaton sales office should be consulted. Sale of the product shown in this literature is subject to the terms and conditions outlined in appropriate Eaton selling policies or other contractual agreement between Eaton and the purchaser.

THERE ARE NO UNDERSTANDINGS, AGREEMENTS, WARRANTIES, EXPRESSED OR IMPLIED, INCLUDING WARRANTIES OF FITNESS FOR A PARTICULAR PURPOSE OR MERCHANTABILITY, OTHER THAN THOSE SPECIFICALLY SET OUT IN ANY EXISTING CONTRACT BETWEEN THE PARTIES. ANY SUCH CONTRACT STATES THE ENTIRE OBLIGATION OF EATON. THE CONTENTS OF THIS DOCUMENT SHALL NOT BECOME PART OF OR MODIFY ANY CONTRACT BETWEEN THE PARTIES.

In no event will Eaton be responsible to the purchaser or user in contract, in tort (including negligence), strict liability or otherwise for any special, indirect, incidental or consequential damage or loss whatsoever, including but not limited to damage or loss of use of equipment, plant or power system, cost of capital, loss of power, additional expenses in the use of existing power facilities, or claims against the purchaser or user by its customers resulting from the use of the information, recommendations and descriptions contained herein. The information contained in this manual is subject to change without notice.

FCC Part 15, Class B

This equipment has been tested and found to comply with the limits for a Class B digital device, pursuant to part 15 of the FCC Rules. These limits are designed to provide reasonable protection against harmful interference in a residential installation. This equipment generates, uses and can radiate radio frequency energy and, if not installed and used in accordance with the instructions, may cause harmful interference to radio communications. However, there is no guarantee that interference will not occur in a particular installation. If this equipment does cause harmful interference to radio or television reception, which can be determined by turning the equipment off and on, the user is encouraged to try to correct the interference by one or more of the following measures:

- Reorient or relocate the receiving antenna.
- Increase the separation between the equipment and receiver.
- Connect the equipment into an outlet on a circuit different from that to which the receiver is connected.
- Consult the dealer or an experienced radio/TV technician for help.

Modifications not expressly approved by the manufacturer could void the user's authority to operate the equipment under FCC rules.

Contents

CONFIGURATION, TROUBLESHOOTING AND SPECIFICATIONS

- Introduction **1**
- Configuration. **2**
 - Inverter display panel 2
 - Customizing default display 2
 - Setting battery type and charge current 3
- Fault codes and troubleshooting **6**
- Troubleshooting **8**
- Charger and AC transfer **9**
- Specifications **10**

INSTALLATION

- Installation types and definitions **15**
- Choose a location for inverter mounting **17**
- Mount the inverter. **18**
- Connect the AC input wires (optional for AC input) **19**
- Connecting AC output wires (optional for hardwire AC output) **21**
- Connecting DC input wires **23**
- Removable display remote mounting **25**
- Test installation **26**

Important safety instructions

WARNING

Limitations on use - The Eaton Inverter is not to be connected to life support devices.

WARNING

Explosion hazard - Working with batteries can be very dangerous. It is crucial to follow all steps completely while servicing the unit. It is possible for the inverter to produce arcs and/or sparks, do not install or use inverter near flammable materials (i.e. gas- powered machines, fuel tanks, or any components connected to a fuel supply). Follow any instructions from the battery manufacturer being used.

CAUTION

Risk of injury - To avoid risk of injury, use only 12Vdc, lead-acid, rechargeable batteries (i.e. GEL, AGM, and Flooded). Other types of batteries may burst, resulting in personal injury and/or damage.

IMPORTANT

- Do not cover/obstruct ventilation systems.
- Use wire in good condition and of appropriate ratings.
- Attachments not recommended by Eaton may be damaging to inverter.
- Do not use inverter after being dropped, hit, or damaged.
- Do not disassemble the inverter. Risk of shock, fire, and void of warranty may result.
- Remove all AC and DC connections before maintenance, cleaning, or circuit work.
- Provide inverter an equipment-grounding conductor connected to AC input ground.
- Insure cables are routed properly, secured and protected from chaffing.

WARNING

Failure to follow these instructions could result in death, personal injury or property damage.

Personal precautions when working with batteries

WARNING

Risk of electrical shock, burn from high short-circuit current, fire or explosion from vented gases.

- Follow the instructions and precautions from the battery manufacturer (i.e. cap removal, or charging rates).
- Follow battery instructions for water and battery acid levels from the battery manufacturer.
- Ventilate the area near the batteries as much as possible.
- Do not smoke or produce flame/spark near engine or batteries.
- Use caution when handling tools around batteries.
- Remove all metal items (i.e. rings, bracelets, watches) from person when working with batteries.
- Work within voice range of other people.
- Wear eye and clothing protection while working, and avoid touching eyes during installation.
- Upon battery acid contacting skin or clothing, wash immediately with soap and water.
- Upon contacting eye(s), flood immediately with running cold water for at least twenty minutes and seek medical attention.

CAUTION

DC connection precaution(s) - Make only DC output connections or disconnections after setting all unit switches to OFF position and opening AC disconnect(s).

CAUTION

Hard wired AC output connection caution - Always use an external GFCI with hard wired AC output. WARNING: Risk of electrical shock. Use only 20A rated GFCI receptacle with UL listing.

NOTES

It is recommended to review TMC RP 160 and RP 163, which include wiring and selection recommendations.

Introduction

The Eaton Inverter is designed to create 1.8kW of pure sine wave 115VAC 60Hz power from a 12V battery source. The units low THD (<2.5% typical) can power sophisticated electronics that may not work with modified sine wave inverters. Unit also has high surge capability to power up hard to start loads like power tools, refrigerators or pumps.

The Eaton Inverter is protected against most abnormal conditions found in the automotive environment.

The unit has an under voltage alarm and shut down that prevents the batteries from becoming depleted.

A warning alarm will sound when the maximum power output is being reached. An alarm will also sound if unit is overheating. If any of these conditions are not corrected, the unit will turn off safely to protect itself.

Some models include a three stage temperature compensated battery charger that maximizes the life of the batteries. It can be configured for AGM, flooded or Gel lead acid batteries.

Eaton inverters include a Shore Power bypass feature. When AC power (Shore Power) is detected at the AC input, the unit powers all accessories from this available power source. If the inverter automatically detects that AC input is removed, it becomes an independent AC supply.

Inverter input current could be as high as 200A in the 1.8KW unit. Special care has to go into evaluating the proper sizing of batteries, wire gauge and length.

The inverter's logic is powered by the 12V input battery. The unit current draw when power is off is typically less than 2mA. When the inverter is turned on with no load connected to its output it will typically draw less than 0.5A.

Operation efficiency is input voltage, load and ambient temperature dependent, but it is typically 90%.

The Eaton inverter will not withstand reverse polarity. Permanent damage will occur and is not covered by warranty.

Configuration guide

This chapter describes inverter operation, configuration and the meaning of error codes.

Setting battery types on main unit (models with battery charger only)

The inverter can operate from and recharge several different types of lead-acid batteries. It is important to make sure the battery type is configured on the unit for optimum charging process before installing batteries. See Table 1.

Customizing display, alarm and charging current settings

The display panel is capable of adjusting the following:

- What is presently displayed on the screen
- Modify the charging current
- Enable/Disable the inverter output
- Enable/Disable the audible alarm
- Modifying the shutdown voltage value
- Select battery type for charging

Table 1.

Battery type setting	Charge voltage VDC (tolerance +/- 0.2Vdc)		
	Bulk	Absorption	Float
Fixed 13.5	13.5	13.5	13.5
Flooded	14.4	14.4	13.5
Gel	14.2	14.2	13.8
AGM	14.3	14.3	13.4

- Set to factory defaults (see Figure 2: Setting flow chart)

To change display and read current inverter settings:

By default, the screen will display the input voltage in [Volts] and the “**Input Voltage (V)**” LED indicator will be illuminated.

1. Press the **SELECT** button once. Screen displays the DC input current in [Amperes] and the “**Input Current (A)**” LED indicator will illuminate.
2. Press the **SELECT** button once more. Screen displays the AC output power in [kilowatts] and the “**Output power (KW)**” LED indicator will illuminate.
3. Press the **SELECT** button once more. Screen displays the Low Voltage Shut Down Level: 11.8, 12.2, 10.5.
4. Press the **SELECT** button once more. Screen displays the alarm setting: AL1 = Alarm on; AL0 = Alarm off.
5. Press the **SELECT** button once more. Screen displays the battery charge current setting.
6. Press the **SELECT** button once more. Screen displays the battery type for charging: FI = Fixed; FLo = Flooded; gEL = Gel, Ag = AGM.

Note: If model equipped with AC bypass switch, selections will vary while in bypass mode.

WARNING

Fire hazard – Programming the incorrect battery type may result in battery damage and a fire risk.

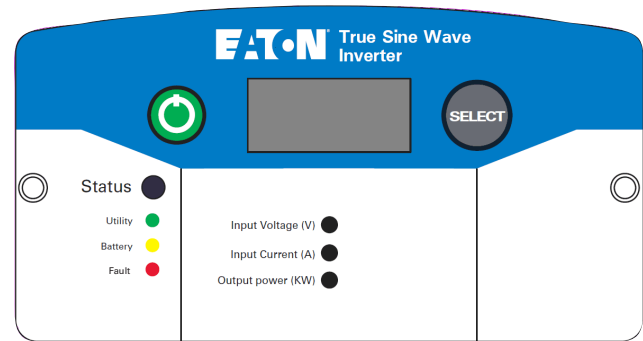

Figure 1. Inverter display panel
Power button located on the left side. SELECT button located on the right.

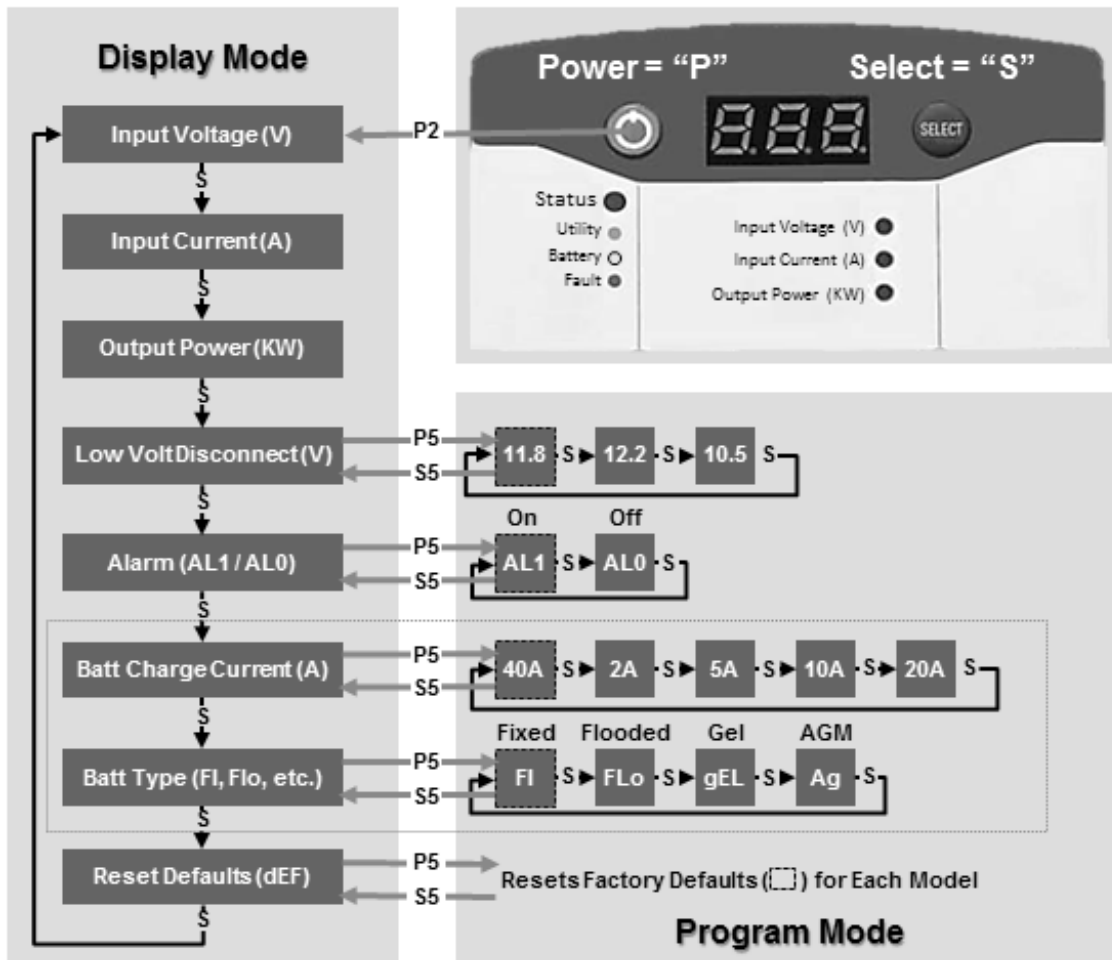

Figure 2. Setting flow chart
Showing all display and setting adjustment options

To adjust the charging current setting:

By default, the charging current is 40A.

To change the charge current setting:

1. Press and hold the **green power button** for approximately 2 seconds. The inverter will beep and the display will flash the input voltage. Press the **SELECT** button until "40" (or current value setting) is displayed. Press and hold the **POWER** button for 5 seconds.
2. Press the **SELECT** button to switch between the different current ratings in [Amps].
 - 40 – 2 – 5 – 10 – 20
3. To choose a new setting, stop at the desired value, press and hold the select button for five seconds to memorize the setting.
4. Confirm the new setting by not touching the inverter for approximately 5 seconds to return to inverter setting display mode. Press **SELECT** button multiple times to confirm new setting(s).

Unit performance can be optimized using Table 2.

Configuration guide

Table 2. Charging current guidelines

AC input circuit branch breaker or fuse size (A)	Charger DC current settings (A)	Max by-pass AC current available (A)*
15	2	13.5
	5	12.5
	10	11
	20	8.5
	40	3.5
20	2	18.5
	5	17.5
	10	16
	20	13.5
	40	8.5
30	2	28.5
	5	27.5
	10	26
	20	23.5
	40	18.5

Note: *Momentarily available

To adjust alarm on/off [AL0, AL1] setting:

By default, the alarm is **ON**.

To change the alarm on/off setting:

1. Press and hold the **green power button** for approximately 2 seconds. The inverter will beep and the display will flash the input voltage. Press the **SELECT** button until "AL" is displayed. Press and hold the **POWER** button for 5 seconds.
2. Press **SELECT** button to toggle between the two alarm on/off settings:
 - "AL0" – this indicates the alarm is **OFF**
 - "AL1" – this indicates the alarm is **ON**
3. To choose a new setting, stop at the desired value, press and hold the select button for five seconds to memorize the setting.
4. Confirm the new setting by not touching the inverter for approximately 5 seconds to return to inverter setting display mode. Press **SELECT** button multiple times to confirm new setting(s).

To adjust low voltage shutdown [11.8, 12.2, 10.5] setting:

By default, the low voltage shutdown setting is **11.8**.

To change the low voltage shutdown setting:

1. Press and hold the **green power button** for approximately 2 seconds. The inverter will beep and the display will flash the input voltage. Press the **SELECT** button until "11.8" (or current setting) is displayed. Press and hold the **POWER** button for 5 seconds.
2. Press **SELECT** button to toggle between the three voltage shutdown settings:
 - 11.8
 - 12.2
 - 10.5

3. To choose a new setting, stop at the desired value, press and hold the **SELECT** button for five seconds to memorize the setting.
4. Confirm the new setting by not touching the inverter for approximately 5 seconds to return to inverter setting display mode. Press **SELECT** button multiple times to confirm new setting(s).

To adjust battery type [FI, FLo, gEL, Ag] setting:

By default, the battery type is **FI, Fixed**.

To change the battery type setting:

1. Press and hold the **green power button** for approximately 2 seconds. The inverter will beep and the display will flash the input voltage. Press the **SELECT** button until "FI" is displayed. Press and hold the **POWER** button for 5 seconds.
2. Press **SELECT** button to toggle between the four battery type settings:
 - "FI" – this indicates Fixed setting.
 - "FLo" – this indicates Flooded battery setting.
 - "gEL" – this indicates Gel battery setting.
 - "Ag" – this indicates AGM battery setting.
3. To choose a new setting, stop at the desired value, press and hold the **SELECT** button for five seconds to memorize the setting.
4. Confirm the new setting by not touching the inverter for approximately 5 seconds to return to inverter setting display mode. Press **SELECT** button multiple times to confirm new setting(s).

To reset factory default settings:

By default, the inverter settings are **max charge current, AL1, 11.8, FI**

To reset these values:

1. Press and hold the **green power button** for approximately 2 seconds. The inverter will beep and the display will flash the input voltage. Press the **SELECT** button until "dEF" is displayed. Press and hold the **POWER** button for 5 seconds.
2. Press and hold the **SELECT** button for five seconds to memorize the setting.
3. Confirm the new setting by not touching the inverter for approximately 5 seconds to return to inverter setting display mode. Press **SELECT** button multiple times to confirm new setting(s).

Fault codes and troubleshooting

Fault codes and troubleshooting

Inverter Section

Table 3. DC Input Warning and Shutdown

- Unit start up voltage (Lo setting): > 10.5 +/- 0.3 VDC and < 16.0 +/- 0.3 VDC
- Unit start up voltage (Mid setting): > 11.8 +/- 0.3 VDC and < 16.0 +/- 0.3 VDC
- Unit start up voltage (Hi Setting): > 12.2 +/- 0.1 VDC and < 16.0 +/- 0.3 VDC

Condition	Disconnect setting	Setting (+/- 0.3V)	Recovery (+/- 0.3V)	Display	Audible Alarm	Comment
Over voltage instant shutdown	Lo, mid or hi	16.0	15.5	E02	Beep @ 1Hz	Notes 1, 2
Under voltage instant shutdown	Lo, mid or hi	10.0	--	--	--	Note 3
Under voltage shutdown	Lo	10.5	12.0	E01	Beep @ 1Hz	Note 4
Under voltage warning	Lo	11.0	11.3	E05	Beep @ 0.33Hz	--
Under voltage shutdown	Mid	11.8	12.3	E01	Beep @ 1Hz	Note 5
Under voltage warning	Mid	11.8	12.1	E05	Beep @ 0.33Hz	--
Under voltage shutdown	Hi	12.2	12.7	E01	Beep @ 1Hz	Note 6
Under voltage warning	Hi	12.2	12.5	E05	Beep @ 0.33Hz	--

Note:

1. Unit will shut down instantly and restart automatically if voltage returns to less than 15.5V within 30 seconds
2. If DC voltage is not less than 15.5V within 30 seconds, unit will require manual reset by power button
3. Unit will shut off instantly if DC voltage drops below 10V regardless of settings
4. Unit will shut off if DC voltage is below shutdown for 10 seconds
5. Unit will shut off if DC voltage is below shutdown for 90 seconds
6. Unit will shut off if DC voltage is below shutdown for 2 minutes

Table 4. AC output overload protection and warning shutdown

Model	Condition	Power (W)	Display	Audible alarm
12-110-1800-xx	Warning (+/- 100W)	2000	E06	Beep @ 0.33Hz
	Shutdown (+/- 100W)	2100	E03	Beep @ 1Hz
12-110-1500-xx	Warning (+/- 100W)	1700	E06	Beep @ 0.33Hz
	Shutdown (+/- 100W)	1800	E03	Beep @ 1Hz
12-110-1250-xx	Warning (+/- 100W)	1450	E06	Beep @ 0.33Hz
	Shutdown (+/- 100W)	1550	E03	Beep @ 1Hz

AC output short circuit protection

A short circuit may be applied to the AC output continuously during inverter mode without damage to any components. Unit will shut down within 10 seconds, and display will indicate 'E03' with the buzzer beeping @ 1 Hz.

Note: Manual reset is required to restart Inverter after AC Overload or Short Circuit shutdown. System will automatically reset AC Overload or Short Circuit shutdown error when utility is available. The supplemental protector or the branch protection specified in the Installation Guide should be open under bypass short circuit output condition.

Incorrect connection protection

Inverter DC input protection

- **AC input and AC output:** AC Input Line and Neutral reverse connection cannot be detected. Input and output ac terminals are labeled and unit should be installed by a professional installer.
- **Charger DC output protection:** Reverse polarity on DC terminal will open the input fuses in the Eaton Inverter. This damage is not covered under warranty.

Table 5.

Model	DC output fuse	
All	2x30A (Auto blade)	Non-user servicable

Table 6. Over temperature protection

Location	Condition	
Charger transformer	>95°C	Max. Charge current reduced to half of full load
	>100°C	Max. Charge current reduced to 0A
AC transfer relay	>70°C	System shutdown (no auto-reset)

Max. charge current resumes normal level when Charger Transformer sensor temperature drops below 90°C

Table 7.

Location	Warning (°C)		Error code / audio alarm	Shutdown°C		Error code / audio alarm
	On	Off		On	Off	
Rectifier diode	>90	<88	E07 / beep @ 0.33Hz	>95	<80	E04 / beep @ 1Hz
Extrusion	>63	<60		>60	<56	

Over temperature shutdown of these sensors is auto reset. Sensor temperature tolerance is +/-5°C

AC output protection

External AC source applied to the inverter AC output may damage the inverter. This damage is not covered by warranty.

STATUS LED Indicator

- Solid Green - Battery connected is fully charged in AC bypass mode
- Flashing Green - Charging is in progress in AC bypass mode
- Flashing Amber - AC input is detected and being qualified in AC bypass mode
- Solid Amber - Inverter AC output is on in inverter mode
- Solid Red - Indicateds an error was found. The digital display shows the fault code

Troubleshooting

Troubleshooting

Tripped GFCI Outlet

If an amber light is displayed on the GFCI outlet, disconnect all loads, then press the reset button. Note: output power must be ON for the test or reset button to function.

Display Fault Codes

The following Fault codes are provided on digital display when system Fault/Warning occurs:

E01

DC Input Under-Voltage Shutdown. Unit is detecting an input DC voltage which is too low and it is shutting down. This fault can be caused by a discharged or undersized battery. Incorrect DC wiring length and gauge or fault DC connection can also cause this fault.

E02

DC Input Over-Voltage Shutdown. This fault could be due to a problem in the vehicle charging system. Unit will resume normal operation when voltage returns to the allowed input voltage range.

E03

Inverter Output Overload (or Short Circuit) Shutdown. Unit is being severely overloaded. Reduce the load. If this fault occurs in shore power mode the unit must be reset. To reset, remove AC loads and turn inverter power off and on.

E04

Inverter Over-Temperature Shutdown. Unit is shutting down to protect itself from thermal damage. Place the unit in a location with lower ambient temperature or improve air flow around the unit.

E05

DC Input Under-Voltage Warning. Unit is detecting an input DC voltage which is too low and it is warning the user that it will shut down within 10 seconds. This fault can be caused by a discharged or undersized battery. Incorrect DC wiring length and gauge can also cause this fault.

E06

Inverter Output Overload Warning. Inverter is detecting an overload and it is warning that it is going to shut down within 10 seconds. Reduce load and inverter will keep operating normally.

E07

Inverter Over-Temperature Warning. Inverter is approaching its maximum operating temperature and it will shut down within 10 seconds. Reduce load or/and move the inverter to a location with lower ambient temperature or better air flow.

E08/E09

Not used

E10

Charger Output Over Voltage Shutdown. Battery charger has detected a battery voltage above normal operating range. Vehicle charging system may be damaged.

E11

Battery not accepting charge. Inverter is trying to charge the battery, but battery voltage is not increasing over time. Battery may be damaged

E12

Transfer Relay Over-Temperature Shutdown. Relay that switches inverter to shore power mode is running at an unusually high temperature and unit it is shutting down to protect itself. This could be due to an overload condition in shore power mode. Reduce the load and unit will return to normal operation

Charger and AC transfer

AC input surge protection

- 175 J MOV is connected across the Line and Neutral of AC Input

Charger DC output over voltage shutdown

- Battery over voltage protection: 16.0 +/- 0.5Vdc (Error code: E10)
- Audio Alarm: Beep @ 1 Hz and AC charger is latched off
- Bypass mode is available
- To reset error code, remove AC Input and turn unit off and on

Dead battery charging

Battery voltage must meet the following conditions or Error code E11 will display:

- Initial battery voltage must be 10V or higher for charge to commence
- In event battery voltage drops below 10V after charge is initiated (added load) maximum time for battery voltage to rise above 10V in Bulk charge: 15 minutes
- Audio alarm: Beep @ 1 Hz and AC charger is latched off following 15 minute delay
- Bypass mode is available
- To reset error code, remove AC Input and cycle unit off and on until reset

Specifications

Specifications

Appendix A is the location for product performance information and electrical specifications for the 1800W Eaton Inverter.

Important: Specs are subject to changes without notice.

Technical specifications

Table 8. Input Voltages

	Low	Mid	High
Nominal DC input	12.5Vdc	13.0Vdc	13.0Vdc
Input voltage operating range	10.5-16.0Vdc	11.8-16.0Vdc	12.2-16.0Vdc
No load input current (inverter on)	< 0.9Adc when input voltage is \geq 11.5Vdc < 1.5Adc when input voltage is < 11.5Vdc		
No load input current (inverter off)	< 1.0mA (inverter button off and no utility power connection)		

All DC voltage tolerances +/- 0.3Vdc

Table 9. AC Outputs

	1800W
Continuous output power	1800W (15A)
Surge output power (5 seconds)	2000W
Surge output power	3600W (300ms)
Operating temperature range	0°C to +50°C
Storage temperature range	-40°C to 85°C
THD (Resistive load)	5% max, 2.5% typical

Output power rated at 25°C, continuous power de-rated linearly to 70% at 50°C. After extreme hot or cold storage, unit requires one hour of 0°C to 25°C storage before operating.

Table 10. AC Transfer

AC input transfer from utility to inverter	95Vac
AC input recovery from inverter to utility	100Vac
Utility to inverter and inverter to utility hysteresis	5Vac minimum
Max AC output by-pass current	20 Arms
AC transfer time - utility to inverter	< 50ms
Time delay on transfer from inverter to utility	20s +/- 2s

Voltages +/- 5V

Table 11. Battery Charger

AC input operating range	95-135Vac
AC input range with full power	105-135Vac
AC input current with no load	<0.50 Arms
Input current full load	11.5 Arms
AC input frequency	60Hz +/- 1Hz
Operating temperature range	0°C to +50°C (allow for 1.5Adc charge current reduction above 40°C)

Table 12. DC Output Voltage

Battery type setting	O/P voltage VDC (tolerance +/- 0.2Vdc)		
	Bulk	Absorption	Float
Fixed 13.5	13.5	13.5	13.5
Flooded	14.4	14.4	13.5
Gel	14.2	14.2	13.8
AGM	14.3	14.3	13.4

Table 13. DC Output Current

Model	Maximum DC output current (Adc)				
	Setting1	Setting2	Setting3	Setting4	Setting5
12-110-1800-B4	2 +/- 0.5	5 +/- 1	10 +/- 1	20 +/- 2	40 +/- 4

Table 14. Fan On/Off Setting

Parameter	Fan on	Fan off
Load	> 500W	< 200W
Extrusion temperature	> 60°C	< 55°C
Rectifier diode	> 70°C	< 60°C

Display panel indicators / switches

- Power On/Off momentary switch
- ‘Select’ momentary switch
- 3 x 7-segment LED display
- ‘STATUS’ LED (tri-color)
- ‘Battery Voltage’ LED (Green)
- ‘Battery Current’ LED (Green)
- ‘Output Power’ LED (Green)
- Remote communication cable, 6-wire, 25ft long

Figure 3. Charge Algorithm

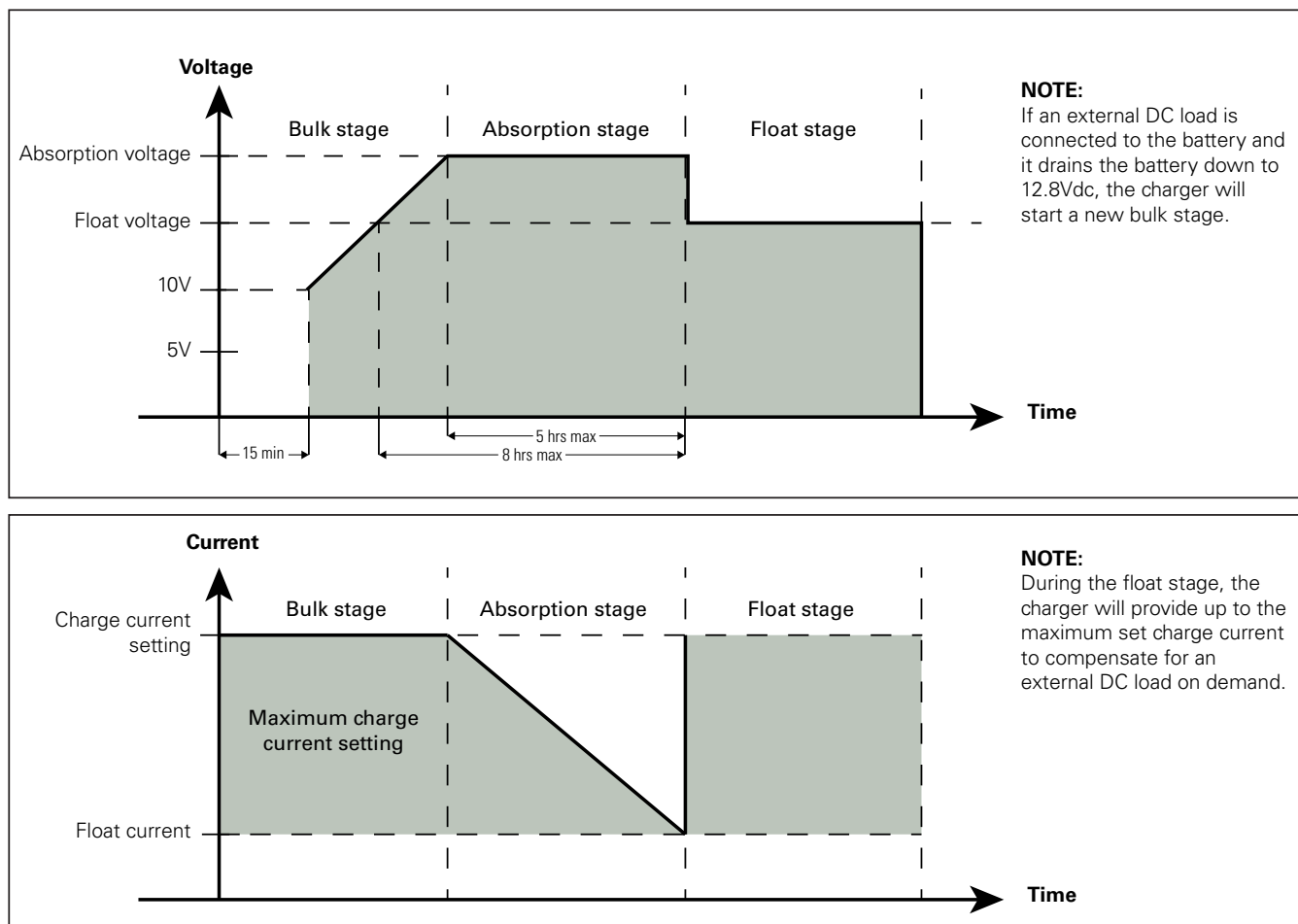

Specifications

Table 15. Mechanical Specifications

Vibration	Per SAE J1455 Rev JAN2011, Sec. 4.10.4.2, Fig. 6-8, 22 hr/axis	Must operate per specification during and after the test.
-----------	--	---

Table 16. Environmental Specifications

Temperature cycling	Per SAE J1455, Rev. JUN2006, Sec. 4.1, Test 4.1.3.1, Fig. 2B	Must operate per specification during and after the test.
Thermal shock	Per SAE J1455, Rev. JUN2006, Sec. 4.1, Test 4.1.3.2 Fig. 2C	Must operate per specification after the test.
Humidity	Per SAE J1455, Rev. JUN2006, Sec. 4.2, Fig. 4B	Must operate per specification during and after the test.
Altitude - operating	Per SAE J1455, Rev. JUN2006, Sec. 4.9, Table 2	Must operate per specification during and after the test.
Altitude – non-operating	Per SAE J1455, Rev. JUN2006, Sec. 4.9, Table 2	Must operate per specification after the test.

Table 17. Electromagnetic Specifications

Conducted immunity	Per SAE J1113/3, Severity Level L6 (0.5W)	Manual restart required for pulses 1, 2b, and 4
Radiated RF immunity - bulk current injection	Per SAE J1113/4, Class C, Region 2, 80mA	
Immunity to radiated RF	Per SAE J1113/25 to 500 MHz Per SAE J1113/27 500 MHz to 2 GHz	
Load dump	Per SAE J1455, Rev. JUN2006, Sec. 4.11.2.2.1	
Jump start test	Per SAE J1455, Rev. JUN2006, Sec. 4.11.1 24 Vdc Applied to DC Terminals	The inverter system should restart without a fault.
Reverse polarity test	Per SAE J1455 Sec. 4.11.1 –24 Vdc Applied to DC Terminals	The inverter shall present no safety hazard. Internal fuses will open in the inverter system, requiring factory service for replacement.

Table 18. Regulatory Requirements

UL458	Comply with the requirements of the standard.	ETLus Mark
CSA C22.2, No. 107.1	Comply with the requirements of the standard.	cETL Mark
47 CFR FCC Part 15, Subpart B, Class B 2016	Comply with the requirements of the standard.	FCC Mark

Mechanical Specifications

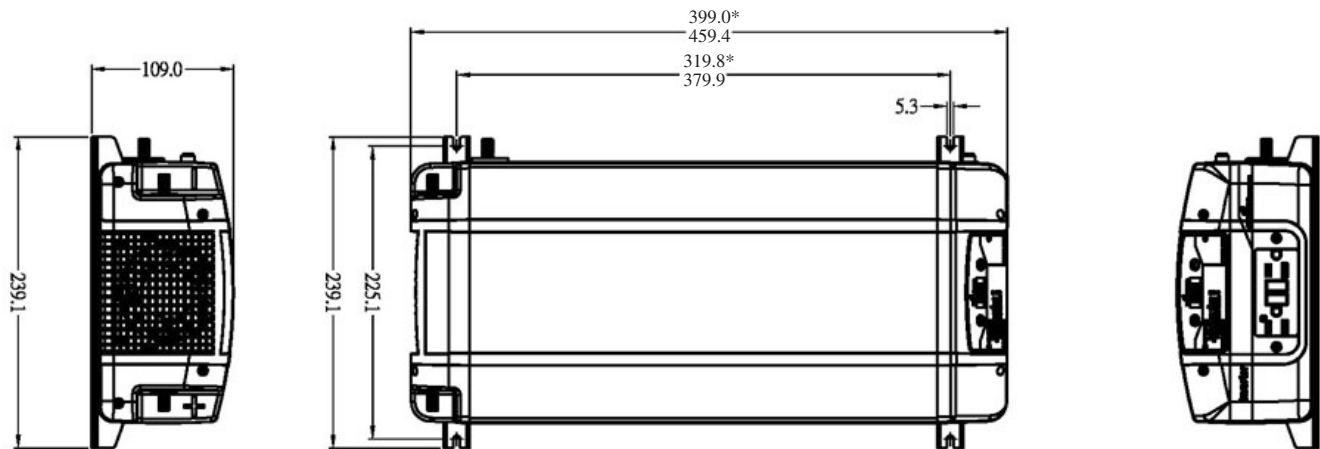

Figure 4. Dimensions (* E models)

Finish: Anodized Aluminum

Terminals: 1045 steel, Bright Tin Plate per ASTM-B545, Class A over, Nickel Plate per ASTM-B689, Type 1

Connectors:

- **DC input:** M8 x 1.25 Stud
- **Chassis ground:** M6 x 1.00 Stud
- **AC output:** AC NEMA outlet with knockouts for AC Input and optional AC output. Built-in AC NEMA outlet is GFCI protected. The built in AC GFCI outlet does NOT control the external AC connections. An external GFCI should be added if using external AC connections.

Weight: Non-E models: 6.8kG [15.0lb], E models: 5.3kG [11.7lb]

Torque DC input cable fasteners to 12.2 -13.6 Nm

Torque chassis ground cable fastener to 6.6 – 7.3 Nm

Installation

Installation

This section offers information as a guide to installing an Eaton Inverter with optional battery charger. It will cover the following:

- Materials list
- Safety instructions
- Sample installation tools and materials
- Installation procedures for mounting and connecting the product ground, AC cabling, DC cabling and grounding techniques

Materials list

The Eaton Inverter package includes the items listed below:

- 1 Eaton Inverter unit
- Owner's / Installation Guide
- 25 foot RJ11 cable for remote mounting of control panel
- 2 ea - M8x1.25 nuts with lock washer and flat washer for battery positive and battery negative
- 1 ea - M6x1.00 nuts with lock washer and flat washer for chassis ground connection
- One red and one black insulating boot for covering up to 00 AWG battery positive and battery negative connections
- 2 ea - NC-38 cable clamps for retention of hardwired AC input and AC output

Safety instructions

 **WARNING**

Shock hazard - All wiring of connectors or otherwise should be done by a technician, electrician or person with electrical experience.

- At the beginning of this guide, there is a section of warnings and cautions; take note of any precautions concerning the installation.
- Prior to engaging in any service, all AC and DC power sources need to be disabled.
- Follow proper cable routing and strain relief guidelines.

Installation codes

Installation codes vary depending on specific industry, location and application of inverter.

It is the installer's responsibility to ensure that all applicable installation requirements are met.

Installation tools and materials

To install the Eaton Inverter, the following tools/materials are recommended:

- Wire strippers – both for wire and cable
- Mounting screws or bolts
- #1 and #2 Phillips screwdriver and small flat blade screwdriver
- Wrench or socket for DC terminals (1/2 inch or 13mm)
- AC cable (i.e. 3-prong, standard wall cable), sized appropriately for load/application
- Wire nuts or crimp connectors for AC wire and appropriate tools
- DC cable, sized appropriately for load/application
- Lugs for DC cables to mount on size M8 x 1.25 studs. DC stud terminals and appropriate tools (i.e. crimping tool)
- Lug for Chassis Ground cable to mount on size M6 x 1.00 stud. DC stud terminal and appropriate tools (i.e. crimping tool)
- Fuse and fuse holder for DC battery connection: 300A
- Optional DC Disconnect Switch

Note: This installation tools and materials list is specific to the inverter installation only. Additional tools and materials may be required for the DC Harness Installation and AC Harness installation (if AC is to be connected)

Definitions

Generator – The inverter is capable of handling most generators that produce nominal 115Vac, 60Hz sine wave AC power. The current limit for DC charging is programmable between 2A-40A, therefore use a generator which will provide sufficient power to satisfy charging requirements.

AC disconnect and over-current protection device – The inverter is required by safety and electrical codes to have AC and DC input/output over-current protection (i.e. circuit breakers and/or fuses), as well as disconnect devices. The following are suggested protective measures for each configuration:

AC input: The branch fuse or branch circuit breaker (hard wired) used on the source of the inverter must be rated no less than 15A or no more than 30A and must also be approved for use on 115Vac systems. The wire used between the breaker and the inverter needs to be sized accordingly to pass the same amount of current rated for the fuse.

AC output: The fuse or circuit breaker on the output should not be rated any higher than that of the input. The wire between the inverter and the AC output breaker should be rated to carry the amount of current rated for the fuse. Any subsequent wiring from this output breaker to the loads must be sized accordingly for the current being passed to each individual load. 1000 Watt models feature an integrated 15 Amp AC output breaker while 1800 Watt models feature an integrated 20 Amp AC output breaker.

Disconnect devices – Each fuse or breaker system requires a method for disconnecting. If the devices used are circuit breakers, these will serve as the disconnects. If they are fuses, separate AC disconnect switches will be necessary ahead of the fuses; these switches will be a branch circuit with proper current characteristics and rated to 120Vac.

AC distribution panels – A usual system will incorporate distribution centers ahead of the inverter and between the inverter and the loads (AC load panel). AC source panels will include a main circuit breaker, serving as the over-current protection and the disconnect switch for the AC power supply. AC load panels can utilize an AC output circuit breaker, and breakers for each subsequent load circuit.

AC cabling – AC cabling includes but is not limited to all wires/cables between the AC source and the inverter, and all the cabling between the inverter and AC outputs (panels, circuit breakers, and loads). Wiring type and size varies with installation and load. Installation codes will recommend solid or stranded wires, overall size of conductors, and type/temperature ratings of insulation around the wire.

Ensure AC breakers and fuses are sized appropriately for current, insulation for voltage, and ambient temperature ratings. Table 19 gives examples of wiring sizes based on the breaker rating. Examples are based on use with a 2-conductor-plus-ground (3-prong) cable rated at 75°C.

AC output neutral bonding – AC input neutral and output neutral must be isolated from each other. This being noted, the neutral conductor of the inverter AC output circuit (i.e. AC output neutral) is automatically connected to the safety ground during inverter operation. When using an AC utility power source and the inverter is in charging mode, this connection is not present.

DC cabling – DC cabling includes but is not limited to all cables and connectors between the batteries, the DC disconnect and breakers/fuses, and the inverter. Heavy truck or RV installations normally require multi-strand, insulated cables for flexibility and durability; they also usually require over-current protection devices. DC cables must be copper and must be rated to at least 75°C. The cables should also terminate with lugs that fit the DC stud terminals on the inverter (m8 x 1.25). Choosing small cables may result in unsatisfactory device functionality.

DC disconnects and over-current devices – The DC system from the inverter to the battery must be equipped with an over-current device and disconnect. Typically this consists of a separate fuse with a DC disconnect. The rating size of the cables must match rating of fuses. Fuse and disconnect should be situated as close as possible to the battery, on the positive cable.

Batteries – The inverter sources input power from a 12VDC deep cycle or dual purpose batteries. The inverter converts the 12VDC input power to 115VAC output.

Ground Fault Circuit Interrupters (GFCIs) – In the case where the current to ground exceeds specified value, a GFCI device will de-energize the circuit. This protects from electric shock and is usually required for wet/damp locations.

Choose a location for inverter mounting

 **WARNING**

Fire and explosion hazard - It is possible for the inverter to produce arcs and/or sparks, do not install or use inverter near flammable materials (i.e. gas-powered machines, fuel tanks, or any components connecting to a fuel supply). Follow any instructions from the battery manufacturer being used.

 **WARNING**

Fire hazard - Ensure the ventilation openings are not covered or obstructed to reduce risk of fire. Installing the inverter in a compact compartment will be detrimental and may result in overheating.

 **IMPORTANT**

Location(s) must conform to these required parameters:

- **Dry:** Do not allow water or other fluids to splash or drip on to the inverter.
- **Cool:** Ambient, air temperature should be between 0°C and 50°C (32°F and 122°F). Power linearly derates from 100% at 25°C to 70% at 50°C.
- **Ventilated:** Provide a minimum of 5 inches (13cm) of clearance at the DC end of inverter for air flow. Also give at least 1 inch (2.5cm) on each side, and 2 inches (5cm) at the AC end. Do not allow ventilation to be obstructed.
- **Safe:** Do not install the inverter in the same compartment as flammable liquids, batteries, or any unsafe materials.
- **Close-in:** Avoid excessive cable lengths, especially between inverter and battery banks.
- **Batteries:** Never allow battery acid to come in contact with the inverter or the wiring to and from the devices. It is also important to be aware of the corrosive gases that may be coming into contact with the inverter.

Mount the inverter

Mount the inverter

To mount:

1. Remove the inverter from packaging and check that all components are present.
2. Select the mounting location (see illustration Figure 6. One of the following approved orientations is required:
 - Under horizontal surface (1)
 - Horizontal position on vertical surface (2)
 - On horizontal surface (3)
3. Using the inverter as a template, mark and drill pilot-holes for the desired mounting location.
4. Fasten the inverter to the mounting surface using pan-head wood or sheet metal screws if mounting to a wall or bulk-head. Do not block vents on bottom of inverter.

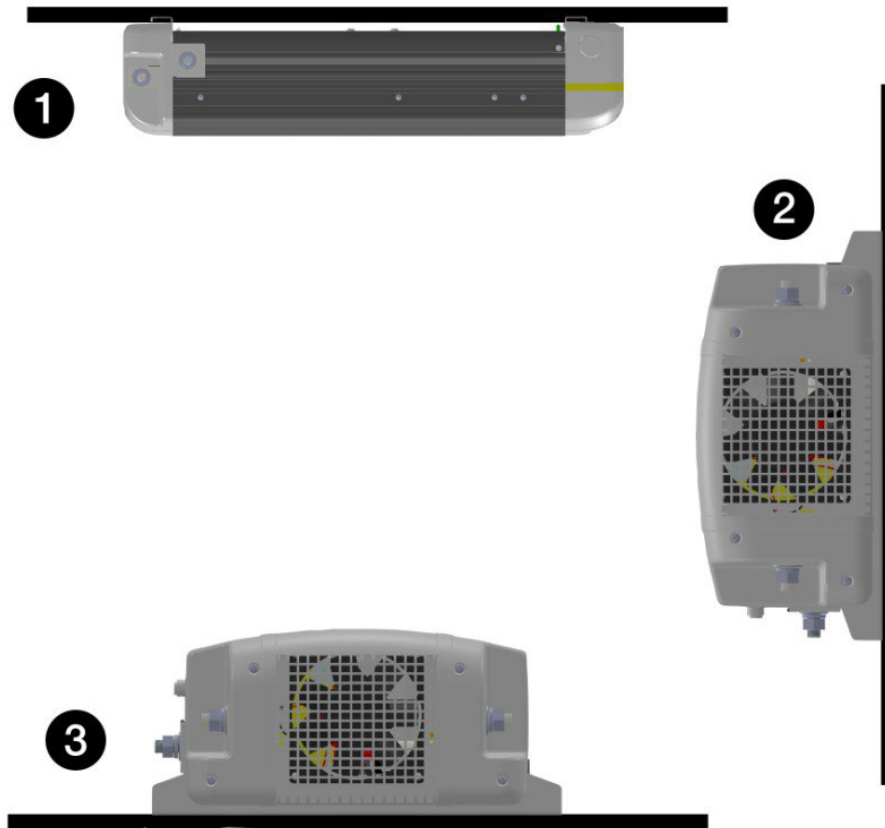

Figure 6. Approved mounting orientation

The inverter has a ground stud on the side near the DC end. Use this to connect the inverter's chassis to ground; usually the vehicle's chassis or DC negative bus ground using a properly insulated copper wire. There are no restrictions on length for the equipment ground cable. General practice is to not have a ground cable within one (1) AWG of the supply cable.

WARNING

Fire hazard - Improper grounding may result in a fire hazard. It is crucial to never operate the inverter without ensuring the equipment is properly connected to ground.

Connect the AC input wires (optional for AC input)

Wire routing guidelines

See Table 19 for suggested cable size for DC input connections and fuse ratings required at the battery end of the positive DC input cable.

Build the cables before rough fitting them to the vehicle. Note any points that will require special attention to avoid chafing or exposure to heat sources. Eliminate potential trouble areas by installing clamps, protecting wiring harnesses with plastic wrap, and installing grommets in feed through holes.

To prevent chafing, cables, plumbing, and installed equipment should not come into hard contact with each other. Because the bodywork and structure can flex during operation, at least a quarter inch clearance is advised between cables and nearby equipment. Do not route cables in high heat areas without adequate thermal protection. Avoid exposure to chemical damage by using protective conduit or wrap.

Torque DC input cable fasteners to 12.2 -13.6 Nm (9-10 ft lbs).

Torque Chassis Ground cable fastener to 6.6 – 7.3 Nm. (5-5.5 ft lbs).

Table 19.

Model	DC Input		AC Input		AC Output	
	Min Wire Size (AWG)	Required Fuse (Amp)	Min Wire Size (AWG)	Branch circuit protection required - recommended fuse (Amp)	Min Wire Size (AWG)	Notes
12-110-1250y	2	150	14	20	14	1, 3
12-110-1250-Bxy	2	150	12	20	14	1, 2, 3
12-110-1500y	2	175	14	20	14	1, 3
12-110-1500-Bxy	2	175	12	20	14	1, 2, 3
12-110-1800y	1	200	12	30	12	1, 3
12-110-1800-Bxy	1	200	10	30	12	1, 2, 3

1. AC output fuse is not required as all models feature a 20A output breaker
2. Suffix 'x' defines battery charger setting: 0, disabled; 4, 40A charger enabled
3. Suffix 'y' defines input under-voltage setting: L, 11.8V; M, multi-select; H, 12.1V

Ensure the GFCI is in its proper location and install the front panel back on to the inverter.

AC wiring WITH an inverter subpanel –

In this wiring configuration, the AC input to the inverter comes from a main AC panel with its own input circuit breaker. The AC output is then routed to a separate inverter subpanel with a dedicated circuit breaker attached.

 **IMPORTANT**

It is important to note the generator must have its own neutral bonded to ground. If the generator's neutral is not bonded to ground, a bonding jumper must be installed. The input AC panel and the inverter subpanel must not have a permanent neutral to ground bond installed.

AC wiring WITHOUT an inverter subpanel

This wiring configuration has the AC input to the inverter coming from an AC source directly. The AC must then be protected by a branch AC breaker or fuse, see Table 19 for fuse recommendations. The AC output is routed to the main AC panel which is protected by AC circuit breakers.

 **IMPORTANT**

It is important to note the generator must have its own neutral bonded to ground. If the generator's neutral is not bonded to ground, a bonding jumper must be installed. In this case, the main AC panel must not install a permanent neutral to ground bond.

Connect the AC input wires (optional for AC input)

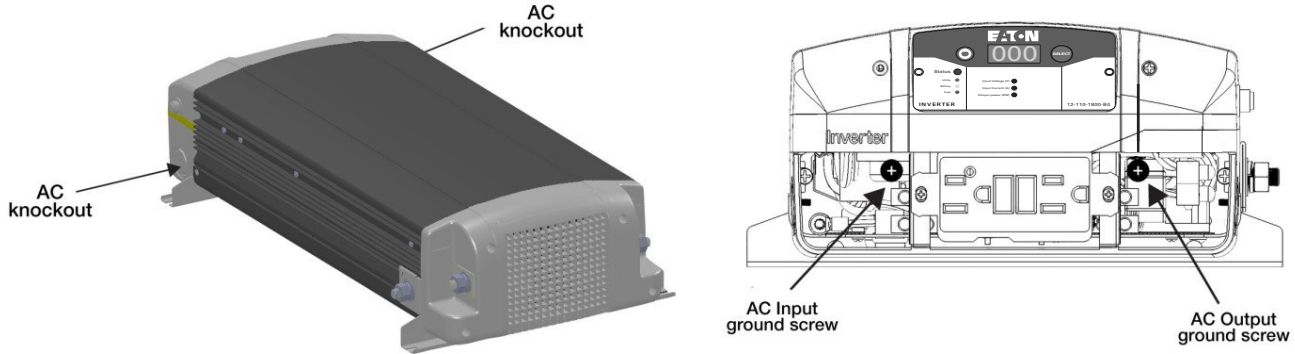

Figure 7. AC wiring compartment

General AC wiring considerations

AC wiring connectors

AC wires are fixed to their respective barrier strip terminals by clamp screws. The amount of insulation to be stripped off the individual wires should not be so much that it is visible outside the connector.

AC and DC Wiring Separation

Do not mix DC and AC wiring configurations. Do not use the same conduit or panel. If wires must cross, only do so at 90° to one another. If necessary, examine applicable codes for specific AC and DC wiring proximity. Figure 7 is an illustration of the AC wiring compartment.

AC wiring and GFCIs

AC input must be hardwired to the inverter. AC loads can either be plugged into the GFCI mounted to the front panel of the inverter, or hardwired directly to the panel. An external GFCI should be used if output is hardwired since the integrated GFCI does not control the AC Output hardwired connections. This section will explain how to hardwire the inverter with AC input and output. All AC wiring (source to inverter, inverter to AC panels, AC panels to circuit breakers, and GFCIs) must be rated to at least the current rating of the fuses and/or circuit breakers, and also must be insulated to at least 120Vac. Multi-strand wire is required. Typically, 30A circuit breaker requires a 10AWG wire.

The knockouts for AC input and output hardwiring are located on the front sidewalls. Make sure to read the labels on the inverter for proper input and output wiring.

AC input connections

1. Ensure AC and DC power are OFF.
2. Install required circuit breaker to the AC input wiring system.
3. Remove mounting screws holding the GFCI AC receptacle and take off the front panel.
4. Leave the GFCI inside the inverter, but remove the knockout from the sidewall.
5. Install the supplied NM clamp (Romex clamp) into the knockout hole.
6. Locate the terminal blocks. The whole area will be labeled "AC INPUT" and there will be three terminations:
 - (GND),
 - (L)
 - (N)
7. Strip enough of the input cable jacket as to expose the three wires, about 2 inches (50mm).
8. Strip approximately 3/8 inches (10mm) of insulation from each wire. The terminal blocks will accept wire sizes up to 10AWG.

Connecting AC output wires (optional for hardwire AC output)

1. Feed the AC input cable into the knockout hole. Facing the front panel of the inverter this should be on the left, and the label should read "AC INPUT."
2. Using a small flat blade screwdriver, loosen the terminal screws.
3. Fasten the ground (GND) wire first.

CAUTION

Reverse polarity – Connecting wires improperly (i.e. the neutral wire into the line termination) will cause the inverter to break down and possibly cause permanent damage.

4. It is very important to not confuse the connections (i.e. putting the line conductor into the neutral termination). From the AC cable, typical wire-color schemes are as follows:
 - BARE COPPER or GREEN or GREEN/YELLOW insulation is GROUND wire
 - BLACK insulation is the LINE wire
 - WHITE insulation is the NEUTRAL wire

Confirm proper wires are in correct termination and tighten screws. Leave some wiring slack inside the compartment.

Note: If there is no need to hardwire the AC OUTPUT, make sure the GFCI is in its proper location and install the front panel back on to the inverter. If hardwiring the AC OUTPUT is required, continue with the procedure below.

Connecting AC output wires (optional for hardwire AC output)

WARNING

Shock, fire and energy hazard - Ensure all sources have been disconnected from power before continuing. Wiring of the inverter should be in accordance with wiring codes.

WARNING

Shock hazard and equipment damage - DO NOT connect any AC input source to the output terminals of the inverter. Connecting an AC voltage source to the output of the inverter will cause serious damage, and possibly hazardous conditions may occur, even if the inverter is OFF.

WARNING

Shock, fire, and energy hazards – Ensure all other wiring systems are disconnected and/or disabled before continuing. Wiring of the inverter should be in accordance with wiring codes. DO NOT connect any AC input source to the output terminals of the inverter.

To make a hardwire connection with the AC OUTPUT of the inverter follow this procedure:

1. Ensure AC and DC power are OFF
2. Install required circuit breaker to the AC load wiring system.
3. Remove the knockout from the sidewall. Do not run the AC input and output wirings through the same knockout.
4. Install the supplied NM clamp (Romex clamp) into the knockout hole
5. Locate the terminal blocks. The whole area will be labeled "AC OUTPUT" and there will be three terminations:
 - (GND), (L), (N)
6. Strip enough of the input cable jacket as to expose the three wires, about 2 inches (50mm).
7. Strip approximately 3/8 inches (10mm) of insulation from each wire. The terminal blocks will accept wire sizes up to 10AWG.

IMPORTANT

The Eaton Inverter will not operate if connected to high-power consumption loads.

The inverter is not meant to operate loads that consume more than 1000 Watts or 1800 Watts (depending on the inverter model being used).

The GFCI AC receptacle has been approved by Eaton and cannot be removed from the inverter. The AC receptacle must be utilized, unless the AC output is hardwired.

An external GFCI should be used if AC output is hardwired since the integrated GFCI does not control the AC Output hardwired connections..

Connecting AC output wires (optional for hardwire AC output)

1. Feed the AC output cable into the knockout hole. Facing the front panel of the inverter this should be on the right, and the label should read "AC OUTPUT."
2. Using a screwdriver, loosen the terminal screws.
3. Fasten the ground (GND) wire first.

 **CAUTION**

Reverse polarity - Connecting wires improperly (i.e. the neutral wire into the line termination) will cause the inverter to break down and possibly cause permanent damage.

4. It is very important to not confuse the connections (i.e. putting the line conductor into the neutral termination). From the AC cable, typical wire-color schemes are as follows:
 - BARE COPPER or GREEN or GREEN/YELLOW insulation is GROUND wire
 - BLACK insulation is the LINE wire
 - WHITE insulation is the NEUTRAL wire

Confirm proper wires are in correct termination and tighten screws. Leave some wiring slack inside the compartment.

5. Connect the AC wires coming from the AC OUTPUT to the AC load panel.

Connecting DC input wires

CAUTION

Shock, fire and energy hazard - Proper polarity must be observed here. Ensure positive is connected to positive, and negative is connected to negative. Perform this observation at the inverter and the battery. Reversing this connection will damage the inverter and will invariably be detected by the manufacturer and void warranty.

The procedure below will illustrate how to connect the battery leads to the terminals on the DC side (back of the inverter). Figure 8 shows the rear of the inverter. Keep the cable lengths as short as possible. Also make sure the cables are rated to a current at least equal to the rating of the circuit breaker or fuse used in line with the cables. It is important the cables are insulated to the correct voltage as well.

Routing DC cables through an electrical distribution panel or battery isolator will result in an undesired, additional voltage drop.

WARNING

Fire hazard - Proper wire must be used in all connections. The temperature rating of the wire must be at least 75°C. All connections must be snug, loose connections may overheat.

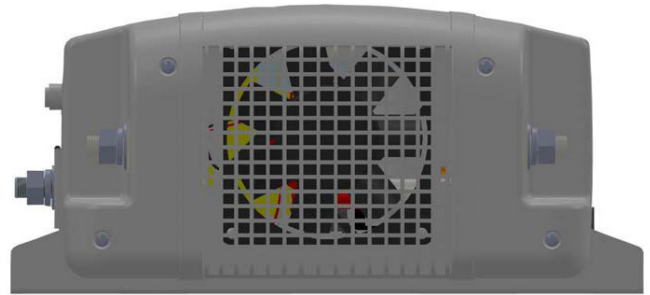

Figure 8. DC end

WARNING

Explosion or fire – DO NOT continue with the following steps if flammable materials or fumes are in the area. Battery disconnect-selector switch must be in OFF position or the following steps may result in explosion or fire. Proper ventilation is crucial.

To make connections to DC terminals:

1. Ensure the inverter is OFF and no connections are being made to DC or AC circuits.
2. Remove nuts and washers from the DC terminals of the inverter.
3. Depending on the size of the connectors chosen, strip about $\frac{3}{4}$ inches of insulation from the cables. The connectors chosen will need to create a permanent, low-resistance connection.
4. Attach terminals to both ends of cables. One end for the connection to the battery, and the other end for connection to the inverter. Confirm no stray wires are left hanging out of the connector or terminal. Connectors should be crimped properly to the cables using approved connectors and tools.
5. Installation of a fuse and fuse holder to the positive cable is required. The fuse must:
 - Be placed on the positive cable and close to the battery
 - Be rated for DC circuits 300A
 - Exhibit an Ampere Interrupting Capacity (AIC) exceeding the short-circuit current available from the battery (Class T fuse).
6. Turn the optional battery disconnect switch to OFF to avoid sparking when making connection. A spark upon initial DC hook up is normal.
7. Attach connector of positive cable to the positive DC terminal of the inverter.
8. Install flat washer then the lock washer and nut back on to the inverter. Tighten the nut to 2-13.6 Nm (9-10 ft lbs) . The connection should be tight enough that the ring terminal does not move on the DC terminal.

CAUTION

A loose connection at any terminal may cause the wires to overheat and melt insulation, they will also cause an excessive voltage drop.

Over-tightening any of the lugs and nuts may cause damage to the DC input terminals.

Connecting DC input wires

CAUTION

Reverse polarity – Permanent fuse damage in the inverter will be caused if the polarity of the wires is switched. Positive must go to positive, and negative must go to negative. Replacement of this fuse must be performed by the manufacturer. Double-check the cable that was just installed is the positive cable connecting the DC terminal of the inverter to the fuse holder. Also ensure the other end of the fuse holder is connected to the positive terminal of the battery.

1. Connect the negative cable from the negative post of the battery to the negative DC terminal of the inverter.
2. Install flat washer then the lock washer and nut back on to the inverter. Tighten to 12.2-13.6 Nm (9-10 ft lbs)

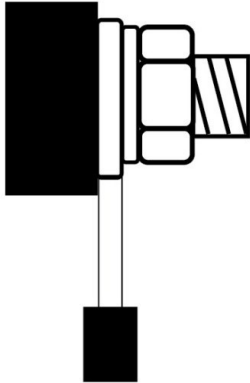

Figure 9. DC cable connections
This is how the terminals should look after installation

Grounding

The grounding lug located on the sidewall of the inverter at the DC terminal end is used to connect the inverter chassis to the battery system's negative connection or grounding bus, as required by electrical regulations. The wiring used for grounding should be bare copper or provided with green insulation. **THIS LUG IS NOT FOR AC GROUNDING.** For heavy trucks or recreational vehicles: use copper wire and connect it between the inverter grounding lug and the vehicle's DC grounding point (vehicle chassis or assigned grounding bus). Tighten to 6.6 - 7.3 Nm. (5 - 5.5 ft lbs)

Removable display remote mounting

If desired, the inverter control panel can be removed and mounted remotely for remote control operation. A 25' communications cable is provided for this purpose.

The communications cable for optional mounting of the display should be at maximum 25 feet. Mounting the display flush into a wall or panel requires an opening about 3.25in x 1.25in and 1.5in deep (8.3cm x 3.2cm and 3.8cm deep).

Mounting the display panel:

1. The location for the panel should be dry, out of direct sunlight, free of corrosive fumes, and suitable for mounting an electronic device.
2. Draw the area to cut away with a pencil on the wall.
3. Cut away the area and pilot-drill the mounting holes into the wall.
4. Put the communication cable into the wall and route to the opening.
5. Put the panel in the opening and fasten it into the wall securely.
6. Route the cable to the inverter and insert the connection into the jack located in the front of the center cavity.

 **IMPORTANT**

The communications cable should not be in parallel or in the same conduit as the AC and/or DC wires. If required, only cross the wires at 90° angles of each other.

Insert connector carefully into jack. Forcing the connector into jack without proper alignment can cause permanent damage.

Test installation

Test installation

WARNING

Shock hazard – AC power from a utility/grid will still pass through the inverter to the AC output even with the inverter turned OFF. Turning the inverter OFF with the button will not disconnect DC or AC input power, this must be done manually.

Note: Prior to system testing assure that the DC fuse is installed and the optional switch is closed. Verify that a minimum of 12.3V is present at the Inverter DC terminals. For best results assure batteries are fully charged.

Prior to use:

1. Verify the inverter is inverting DC battery power AND delivering AC power to the outputs.
2. For installations where AC input and output are hardwired to the inverter, verify the inverter transfers from inverter power to utility/grid power when the utility/grid power is present.

Testing in INVERTER MODE

1. If hardwired, ensure utility/grid power is not present.
2. Press the Power button \approx 1 second to turn the inverter on. The status LED on the panel will glow yellow and the display screen will illuminate.
3. Using an appliance within the inverter's range, plug it into the GFCI on the front of the inverter, or plug it into an AC outlet hardwired to the inverter.
4. Turn ON the appliance and verify it functions properly.

Hint: If the appliance functions as expected, the installation is a success! If it was a hardwire installation, continue reading.

Testing in UTILITY/GRID MODE

1. Using the same appliance from the previous test (must be within power range of inverter), plug it into the GFCI of the inverter.
2. Connect the utility/grid power source.

Hint: The inverter will transfer the appliance to utility/grid power. The status LED on the panel will change from yellow to a flashing yellow for \approx 20 sec and then green. If the appliance then functions as expected, the installation is a success!

Note: If the INVERTER button on the inverter is ON, the inverter will automatically supply the appliance(s) with inverted power from the battery upon the utility/grid power source failing or becoming disconnected. The same will happen if the utility/grid voltage falls too low (less than \approx 90Vac).

WARNING

Shock hazard – When a battery is connected to the DC input (*), utility/grid power will always pass through the inverter to the AC output even if the inverter is turned OFF.

Note: *Battery needs to be connected properly to the inverter and have a minimum voltage of 11V

STATUS LED Indicator

- Solid Green - Battery connected is fully charged in AC bypass mode
- Flashing Green - Charging is in progress in AC bypass mode
- Flashing Amber - AC input is detected and being qualified in AC bypass mode
- Solid Amber - Inverter AC output is on in inverter mode
- Solid Red - Indicateds an error was found. The digital display shows the fault code



Eaton
1000 Eaton Boulevard
Cleveland, OH 44122
United States
Eaton.com

© 2019 Eaton
All Rights Reserved
Publication No. IM SP180164
August 2017

Eaton is a registered trademark.

All trademarks are property
of their respective owners.